

Performance Analysis of MIMO OFDM System for Different Modulation Schemes under Various Fading Channels

Nisha Achra¹, Garima Mathur², Prof. R.P. Yadav³

M. Tech.Scholar, EC Deptt., JEC Kukas, Jaipur, India¹

Research Scholar, EC Deptt., M.N.I.T, Jaipur, India²

Vice Chancellor RTU Kota, India³

Abstract: MIMO-OFDM (Multiple Input Multiple Output Orthogonal Frequency Division Multiplexing) system has been recognized as one of the most popular and competitive technique in a wireless environment nowadays. The performance is calculated in terms of Bit Error Rate (BER) versus the Signal to Noise Ratio (SNR). In this paper we discuss the BER performance of the MIMO-OFDM system with two different equalizers (ZF and MMSE) for various modulation techniques i.e. BPSK, QPSK, 16-QAM and 64-QAM using multipath fading channels i.e. AWGN (Additive White Gaussian Noise), Rayleigh and Rician channel. The multicarrier modulation is employed, which gives advantages like inter symbol interference (ISI) reduction, high data rate, higher reliability, and better performance in multipath fading. The simulation results show that, with MMSE and ZF equalizers, the BER performances is better in MMSE equalizer. Further we analyzed in different fading channels for various modulation techniques in both the equalizers.

Key words: OFDM, ZF and MMSE Equalizer, Multipath fading channels.

I. INTRODUCTION

Wireless communications can be regarded as the most significant and important development in a modern society. Wireless communication systems need tremendously high data rates and high transmission reliability in order to meet the hastily increasing demand for multimedia applications such as high quality audio and video. Existing wireless technologies cannot efficiently support high data rates,

because of these technologies are very sensitive to fading. In present day's communication, OFDM [1] is a widespread and one of the most promising modulation techniques. It is beneficial in many areas such as high spectral efficiency, robustness, low computational complexity, frequency selective fading, and ease of implementation using IFFT/FFT and equalization schemes. Recently, there have been a lot of interest to use OFDM in combination with a MIMO [2] transceiver system, named MIMO OFDM [3][6] system; which is used to increase the diversity gain and system capacity. MIMO as the name indicates; used multiple inputs at the transmitter and multiple outputs at the receiver end which is advantageous rather than a single transceiver (SISO-Single input Single output) systems. MIMO wireless systems are

Motivated by two vital goals: high-data-rate and high performance. This combination of MIMO OFDM is a very promising feature since OFDM able to sustain of more antennas since it simplify equalization in MIMO systems. Usually in OFDM, fading is considered as a

problem in wireless network but MIMO channels uses the fading to increase the capacity of the entire communication network. MIMO is a frequency-selective technique. OFDM can be used to convert such a frequency-selective channel into a set of parallel frequency-flat sub channels. MIMO-OFDM technology has been investigated as the infrastructure for the next generation wireless/ multimedia networks.

II. MIMO-OFDM

OFDM System Model: Figure 1 represents the basic block diagram of OFDM [4][5] system, consist of transmitter and receiver two sections, named OFDM transceiver system.

The data bits inserted from the source are firstly mapped (BPSK, QPSK, 16-QAM, 64-QAM) using given modulation techniques and after that converted from serial to parallel through convertor. Now N subcarriers are there and each sub-carrier consists of data symbol $X(k)$ ($k=0,1,\dots,N-1$), where k shows the sub-carrier index. These N subcarriers are provided to inverse fast Fourier transform (IFFT) block. After transformation, the time-domain OFDM signal at the output of the IFFT [5][6] can be written as:

$$x(n) = \sum_{k=0}^{N-1} X(k) \exp\left(j \frac{2\pi kn}{N}\right), \quad (1)$$
$$0 \leq n \leq N - 1$$



where n is the time domain sample index of an OFDM signal.

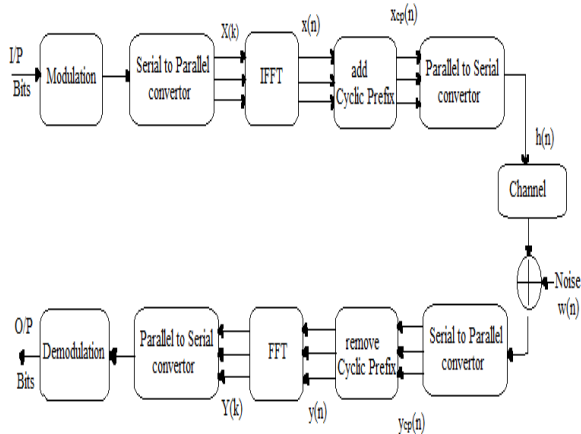

Fig. 1. Block Diagram of a Baseband OFDM transceiver System

After that, Cyclic Prefix (CP) [7] is added to mitigate the ISI effect. We get signal $x_{cp}(n)$, which is sent to parallel to serial convertor again and then, this signal is sent to frequency selective multi-path fading channels [5][8] and a noisy channel with i.i.d. AWGN noise. We used three fading channels in the paper i.e. AWGN, Rayleigh and Rician [8]. The received signal can be given by

$$y_g(n) = x_g(n) * h(n) + w(n), \quad 0 \leq n \leq N - 1 \quad (2)$$

where $w(n)$ i.i.d. additive white Gaussian noise sample and $h(n)$ is the discrete time channel impulse response (CIR).

At the receiver, firstly serial to parallel conversion occurs and cyclic prefix removed. After removing the CP, the received samples are sent to a fast Fourier transform (FFT) block to demultiplex the multi-carrier signals. Then the output of the FFT [5] in frequency domain signal on the k^{th} receiving subcarrier can be expressed as:

$$Y(k) = \frac{1}{N} \sum_{n=0}^{N-1} y(n) \exp\left(-j \frac{2\pi kn}{N}\right) = X(k)H(k) + W(k) \quad 0 \leq k \leq N - 1 \quad (3)$$

where $W(k)$ is noise in time domain and $H(k)$ is the channel frequency response.

MIMO System Model: In MIMO system there is a channel/path between each of the transmitters and each of the receiver antennas [9]. If well spacing is there between the transmitting and the receiving antennas, then we achieved sufficiently uncorrelated received signals.

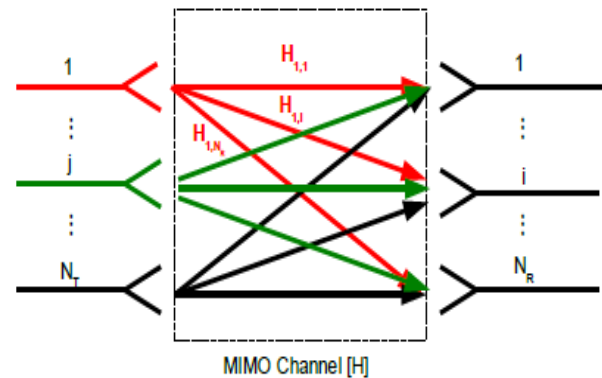

Fig. 2. MIMO System along N_T transmit and N_R receive antennas

Let us assume a MIMO system with N_T transmit antennas and N_R receive antennas as shown in figure 2. For simplicity we consider only flat fading; i.e., the fading is not frequency selective, then a matrix of dimension $N_R * N_T$ with complex transfer factors $H_{i,j}$, can easily express the channel behavior.

$$[H] = \begin{bmatrix} H_{1,1} & H_{1,2} & \dots & H_{1,N_T} \\ H_{2,1} & H_{2,2} & \dots & H_{2,N_T} \\ \vdots & \vdots & \ddots & \vdots \\ H_{N_R,1} & H_{N_R,2} & \dots & H_{N_R,N_T} \end{bmatrix} \quad (4)$$

Here H is the channel matrix and it is also known as the channel transfer function.

If X represents the vector consisting of the streams transmitted from the transmitting antennas and R represents the received signal vector, then the transmitted samples go through the multipath channel and would reach at the receiver. This could be represented as,

$$R = HX + n \quad (5)$$

Where n is the noise of the same size as R with zero mean and variance σ_d^2 (white noise) and X is $1 * N_T$ vector and y is $N_R * 1$ vector.

III. CHANNEL DESCRIPTION

We choose three most widely used channels in our paper: AWGN, Rayleigh and Rician fading channels.

AWGN Channel: Additive white Gaussian noise (AWGN) channel is a basic or commonly used channel model for analyzing modulation schemes. In this model, the AWGN channel adds a white Gaussian noise to the signal that passes through it. This implies that the channel's amplitude frequency response is flat (thus with unlimited or infinite bandwidth) and phase frequency response is linear for all frequencies so that modulated signals go through it without any amplitude loss and phase distortion. Fading does not exist for this channel. The transmitted signal gets distorted only by AWGN process.



AWGN channel is a standard channel used for analysis purpose only.

The mathematical expression in receiving signal is:

$$r(t) = s(t) + n(t) \quad (6)$$

that passes through the AWGN channel where $s(t)$ is transmitted signal and $n(t)$ is background noise or additive white Gaussian noise [10].

Rayleigh Channel: The effects of multipath embrace constructive and destructive interference, and phase shifting of the signal. This causes Rayleigh fading. There is no line of sight (NLOS) path means no direct path between transmitter and receiver in Rayleigh fading channel [9]. The received signal can be simplified to:

$$R(n) = \sum h(n, \tau) S(n - m) + w(n) \quad (7)$$

Where $w(n)$ is AWGN noise with zero mean and unit variance, $h(n)$ is channel impulse response i.e.

$$h(n) = \sum \alpha(n) e^{-j\theta(n)} \quad (8)$$

Where $\alpha(n)$ and $\theta(n)$ are attenuation and phase shift for n^{th} path.

If the coherence bandwidth of the channel is larger than signal bandwidth, the channel is called flat; otherwise it is frequency-selective fading channel. In this paper, MIMO OFDM is simulated under frequency-selective fading channel.

The Rayleigh distribution [11] is basically the magnitude of the sum of two equal independent orthogonal Gaussian random variables and the probability density function (pdf) given by:

$$p(z) = \frac{z}{\sigma^2} e^{-\frac{z^2}{2\sigma^2}}, z \geq 0 \quad (9)$$

where σ^2 is the time-average power of the received signal and eq. (9) is called a **Rayleigh random variable**.

Rician Channel: In environments where there is a dominant Line-of-Sight (LOS) path between the transmitter and the receiver, the complex Gaussian distributed fading coefficient should be modeled with a non-zero mean, giving rise to the Rician fading. Or also say that, Rayleigh fading with a strong line of sight (LOS) content is said to have a Rician distribution, or to be Rician fading.

The Rician distribution is usually characterized by the Rice factor κ ,

$$\kappa = \frac{m}{2\sigma^2} \quad (10)$$

which shows the relative strength of the direct LOS path component of the fading coefficient. When $\kappa = 0$ this

model reduces to Rayleigh fading and as $\kappa \rightarrow \infty$ the fading becomes deterministic giving grow to an AWGN channel.

IV. SIGNAL DETECTION OF MIMO-OFDM SYSTEM

MIMO-OFDM detection methods consist of linear and nonlinear detection methods. We are using only linear detection methods in this paper.

Zero Forcing Equalizer: This is a linear equalization algorithm used in communication systems, which inverts the frequency response of the channel at the receiver to restore the signal before the channel [12]. ZF algorithm considers as the signal of each transmitting antenna output as the desired signal, and consider the remaining part as a disturbance, so the mutual interference between the different transmitting antennas can be completely neglected. ZF equalizers ignore the additive noise and may considerably amplify noise for channels with spectral nulls. Mathematical expression of sub-channel in the MIMO-OFDM system is as follows:

$$R(k) = H(k) X(k) + n(k) \quad (11)$$

Where, $R(k)$, $X(k)$ and $n(k)$ respectively expresses output signal, the input signal and noise vector of the (k) sub-channels in MIMO-OFDM system. The relation between input $X(k)$ and output signal $R(k)$ as in eq. 11 exploits that this is a linear equalizer.

A ZF detection algorithm for MIMO OFDM is the most simple and basic algorithm, and the basic idea of ZF algorithm is kept of MIMO-channel interference by multiplying received signal and the inverse matrix of channel matrix. Zero- Forcing solution of MIMO-OFDM system is as follows:

$$X_{ZF} = H^{-1} R = x + H^{-1} n \quad (12)$$

in which H^{-1} is the channel matrix for the generalized inverse matrix.

Minimum mean square error (MMSE) equalizer: A MMSE estimator is a method in which it minimizes the mean square error (MSE), which is a universal measure of estimator quality [12]. The most important characteristic of MMSE equalizer is that it does not usually eliminate ISI totally but instead of minimizes the total power of the noise and ISI components in the output.

Let us assume that x be an unknown random variable and R be a known random variable, then

$$R = HX + n .$$

An estimator $\hat{x}(R)$ is any function of the measurement y , and its mean square error is given by



$$MSE = E\{(\hat{X} - X)^2\} \quad (13)$$

where the expectation is taken over both X and R . The MMSE always performs better than the ZF equalizer and is of the same complications of implementation.

V. BIT ERROR RATE (BER)

In digital transmission, the no. of bit errors is the number of receiving bits of a signal data over a communication channel that has been changed because of noise, noise, distortion, interference or bit synchronization redundancy.

The bit error rate or bit error ratio (BER) is defined as the rate at which errors occur in a transmission system during a studied time interval. BER is a unit less quantity, often expressed as a percentage or 10 to the negative power.

The definition of BER can be translated into a simple formula:

$$BER = \text{number of errors} / \text{total number of bits sent}$$

Noise is the main enemy of BER performance. Quantization errors also reduce BER performance, through unclear reconstruction of the digital waveform. The precision of the analog modulation/ demodulation process and the effects of filtering on signal and noise bandwidth also influence quantization errors.

VI. SIGNAL TO NOISE RATIO (SNR)

The SNR is the ratio of the received signal power over the noise power in the frequency range of the process. SNR is inversely related to BER, that is high BER causes low SNR. High BER causes an increase in packet loss, enhance in delay and decrease throughput. SNR is an indicator usually measures the clarity of the signal in a circuit or a wired/wireless transmission channel and measure in decibel (dB). The SNR is the ratio between the wanted signal and the unwanted background noise.

$$SNR = \frac{P_{signal}}{P_{noise}} \quad (14)$$

SNR formula in terms of diversity:

$$BER \propto \frac{1}{SNR^d} \quad (15)$$

VII. SIMULATION RESULTS & DISCUSSION

Simulation parameters chosen are listed in Table 1.

Parameters	Value
Modulation	BPSK, QPSK, 16QAM, 64QAM
Channel model	AWGN, Rayleigh, Rician

Noise model	i.i.d. AWGN
FFT & IFFT Point	64
Sub-carrier Number	52
Used sub carrier index	{-26 to -1, +1 to +26}
CP Length	16
OFDM symbol length	4μs

Table-1
 Simulation Parameters for MIMO OFDM

In this section simulation results are shown by using two equalizers (ZF and MMSE) in MIMO OFDM system. Various fading channels i.e. AWGN, Rayleigh and Rician fading channels have been determined for different modulation techniques i.e. BPSK, QPSK, 16-QAM and 64-QAM. We analyze the BER performance of data transmission for BPSK, QPSK, 16-QAM and 64-QAM in Matlab software.

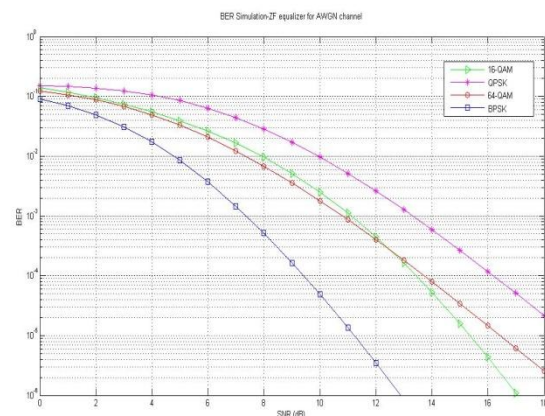

Fig 3. BER for MIMO-OFDM using ZF Equalizer for AWGN channel

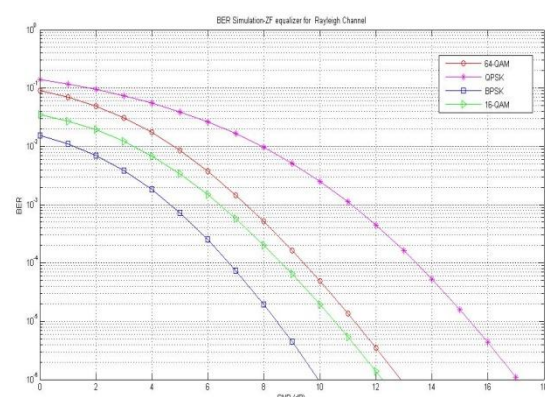



Fig 4. BER for MIMO-OFDM using ZF Equalizer for Rayleigh channel

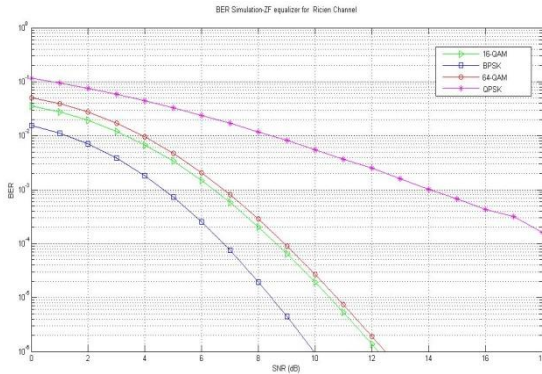

Fig 5. BER for MIMO-OFDM using ZF Equalizer for Rician channel.

Graphs 3, 4 and 5 present the BER values as a function of varying SNR for the MIMO-OFDM system for the ZF equalizer with AWGN, Rayleigh and Rician channels respectively. Through all of the graphs we analyzed that the BPSK modulation gives the least bit error rate, means it is an effective method for data transmission in all of the modulations and for all the channels in terms of bit error rate. For BPSK at the BER value of 10^{-4} we get SNR value of 9.5 dB for AWGN channel in graph 3, 6.75 dB for Rayleigh and Rician channel in graph 4 and graph 5. It represents that Rician and Rayleigh channel behaves similar and better than AWGN channel.

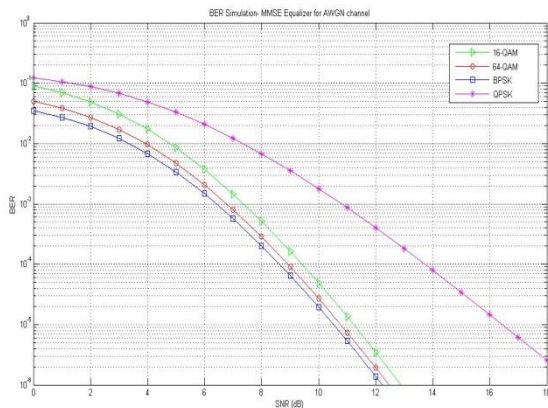

Fig.6. BER for MIMO-OFDM using ZF Equalizer for Rician channel

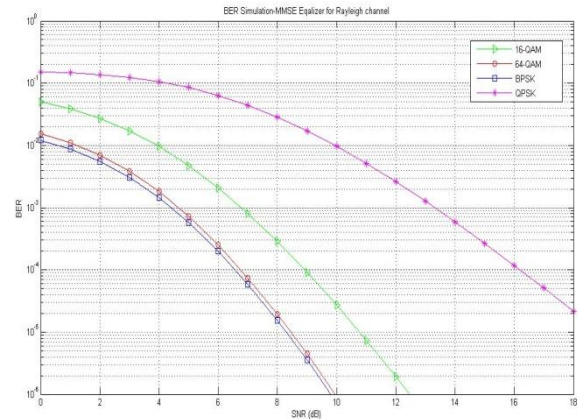

Fig.7. BER for MIMO-OFDM using MMSE Equalizer for Rayleigh channel

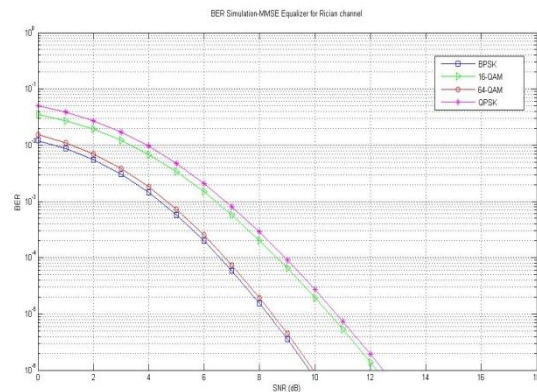

Fig.8. BER for MIMO-OFDM using MMSE Equalizer for Rician channel

Figure 6, 7 and 8 shows the graphs of MIMO OFDM for MMSE equalizer with AWGN channel, Rayleigh channel and Rician channel respectively again. Here also simulation results show that BPSK is performing best in all the modulations because of less bits per symbol. For BPSK at the BER value of 10^{-4} we get SNR value of 8.75 dB for AWGN channel in graph 6, 6.5 dB for Rayleigh and Rician channel in graph 7 and graph 8. It represents the channel behavior for MMSE in which Rician and Rayleigh channel behaves same but better than AWGN channel.

When we made comparative analysis of ZF and MMSE equalizer through given values of BPSK above, it is clearly seen that that BER using ZF equalizer is more than the BER using MMSE equalizer. Means MMSE equalizer behaves better than ZF equalizer.

VIII. CONCLUSION

According to the simulation parameters, we can get the following conclusions: BER is clearly low for BPSK, so this is the best modulation technique for data transmission on all the channels used and also for both the equalizers.



Comparing with BPSK modulation, 64-QAM, then 16-QAM and then the QPSK modulation is more sensitive to fading for MMSE equalizer. But for ZF equalizer, when comparing with BPSK modulation, 16-QAM, then 64-QAM and then the QPSK modulation is more sensitive to fading. And also MMSE equalizer outperforms ZF equalizer.

Further work can be extended with other channels i.e. Nakagami- m channels and with different higher order modulation techniques. Also performance can be evaluated using other novel equalizers.

REFERENCES

- [1]. Bhasker Gupta, Gagan Gupta, and Davinder S. Saini, "BER Performance Improvement in OFDM System with ZFE and MMSE Equalizers", *IEEE Communications Letters*, vol.-6, no.,pp. 193-197, April 2011.
- [2]. D. Gesbert, M. Shafi, Da-shan Shiu, P. J. Smith, A. Naguib, "From theory to practice: an overview of MIMO space-time coded wireless systems", *Selected Areas in Communications*, *IEEE Journal*, vol.-21, pp. 281 -302, April 2003.
- [3]. M. Jiang and L. Hanzo, "Multiuser MIMO-OFDM for next generation wireless systems," In *Proceedings of IEEE*, vol.-95, Issue 7, pp. 1430-1469, July 2007.
- [4]. Kuixi Chen, Jihua Lu, Bo Yang, Zhilun Li and Zibin Zhang, "Performance Analysis of an OFDM Transmission System Based on IEEE802.11a" *IEEE Communications Letters*, pp. 1-6, Oct. 2011.
- [5]. Tian-Ming Ma, Yu-Song Shi, and Ying-Guan Wang, "A Low Complexity MMSE for OFDM Systems over Frequency-Selective Fading Channels", *IEEE Communications Letters*, vol.-16, no.-3, March 2012.
- [6]. Allert van Zelst and Tim C. W. Schenk, "Implementation of a MIMO OFDM-Based Wireless LAN System," *IEEE Transaction on Signal Processing*, vol.-52, Issue 2, pp. 483-494, February 2004.
- [7]. Mitalee Agrawal and Yudhishtir Raut, "BER Analysis of MIMO OFDM System for AWGN & Rayleigh Fading Channel", *International Journal of Computer Applications*, vol.-34, no.-9, November 2011.
- [8]. T. S. Rappaport, *Wireless Communications, Principles and Practice* 2nd ed., Pearson Edu., vol.-1, pp. 356-376, 2002.
- [9]. Kai Yu and Bjorn Ottersten, "Models for MIMO Propagation Channels, A Review", in *Special Issue on "Adaptive Antennas and MIMO Systems"*, *Wiley Journal on Wireless Comm. and Mobile Computing*, vol.-2, Issue 7, pp. 653-666, November 2002.
- [10]. Van de Beek, J. Edfors, O. Sandell, M. Wilson, S.K. Borjesson and P.O., "On channel estimation in OFDM systems", In *proceedings of 45th IEEE Vehicular Technology Conference*, vol.-2, Issue 7, pp. 815-819, 1995.
- [11]. Pallavi Bhatnagar, Jaikaran Singh, Mukesh Tiwari, "Performance Of MIMO-OFDM System For Rayleigh Fading Channel", *International Journal Of Science And Advanced Technology*, vol.-1, no.-3, May 2011.
- [12]. Jin-Sung Kim, Sung-Hyun Moon, and Inkyu Lee, "A New Reduced Complexity ML Detection Scheme for MIMO Systems" *IEEE Journals and Magazines*, vol.-58, Issue 4, pp. 1302 - 1310, April 2010.

BIOGRAPHY

1. **Prof. Raj Kumar Gupta**, Ex-Principal, M.N.I.T, Jaipur.
2. **Prof. M. M. Sharma**, Principal, Govt. Engineering College Ajmer NH-8, Barliya Circle, Ajmer (Rajasthan), 305002.
3. **Prof. K. C. Roy**, Professor, ECE Dept. SBCET College, Jaipur (Rajasthan), 302012.