

# Irrigation System Using a Wireless Sensor Network and GPRS

Suraj S. Avatade<sup>1</sup>, Prof. S. P. Dhanure<sup>2</sup>

PG Student, Dept. of Electronics and Telecommunication, SITS, Narhe, Pune, India<sup>1</sup>

Assistant Professor, Dept. of Electronics and Telecommunication, SITS, Narhe, Pune, India<sup>2</sup>

**Abstract:** This project probes into the design of the automated irrigation system based on ARM microcontroller. This Embedded project is to design and develop a low cost feature which is based on embedded platform for water irrigation system. Optimum use of water is main objective of this irrigation system to reduce water consumption. This project uses temperature and soil moisture sensors to detect the water quantity present in agriculture and water level sensor for detect water level in tank. Aim of this embedded project is to monitor status of the sensors on remote PC through a web page. Here temperature and soil moisture sensors and water level can be monitored on web page through micro controller. The web-server is connected to the internet. By typing the IP-address on the web browser, the owner gets a web page on screen. This page contains all the information about the status of the sensors and ON/OFF status of the motor.

**Keywords:** Automation, Internet, Irrigation system, Wireless Sensor Network (WSN).

## I. INTRODUCTION

Indian economy is basically depends on agriculture. Agriculture uses most of available fresh water resources and this use of fresh water resources will continue to be increases Because of population growth and increased food demand. Increased labour costs, stricter Environmental regulations and increased competition for water resources from urban areas Provide strong motivation for efficient Irrigation system. The automated irrigation system is feasible and cost effective for optimizing water resources for agricultural production. Using the automated irrigation system we can prove that the use of water can be reduced for different agricultural production. The irrigation system provide only required amount of water to crop. This automated irrigation system allows it to be scaled up for larger greenhouses or open fields. An automated irrigation system was developed to optimize water use for agricultural crops. The system has a distributed wireless network of soil moisture and temperature sensors placed in the root zone of the plants and water level sensor is placed in tank for checking the water level in tank. In addition, a gateway unit handles sensor information, triggers actuators, and transmits data to a web application. An algorithm was developed with threshold values of temperature, soil moisture and water level that was programmed into a micro-controller based gateway to control water quantity.

## II. AN OVERVIEW ON SOME PREVIOUS IRRIGATION SYSTEM

In some of the irrigation system irrigation scheduling is achieved by monitoring soil, water status with tension meters under drip irrigation by the automation controller system in sandy soil. It is very important for the farmer to maintain the content in the field. In this the design of a Micro-controller based drip irrigation mechanism is proposed, which is a real time feedback control system for

monitoring and controlling all the activities of drip irrigation system more efficiently. Irrigation system controls valves by using automated controller allows the farmer to apply the right amount of water at the right time, regardless of the availability of the labour to turn valves[1]. Some irrigation systems are used to implement efficient irrigation scheme for the field having different crops. The system can be further enhanced by using fuzzy logic controller. The fuzzy logic scheme is used to increase the accuracy of the measured value and assists in decision making [2]. The green house based modern agriculture industries are the recent requirement in every part of agriculture in India. In this technology, the humidity and temperature of plants are precisely controlled. Due to the variable atmospheric conditions sometimes may vary from place to place in large farmhouse, which makes very difficult to maintain the uniformity at all the places in the farmhouse manually. For this GSM is used to report the detailed about irrigation. The report from the GSM is send through the android mobile [3]. The software and hardware combine together provide a very advanced control over the currently implemented manual system. The implementation involves use of internet for remote monitoring as well as control of Drip Irrigation system. This system uses sensors like humidity, soil moisture. These sensors send values to micro-controller. Micro-controller sends values to PC using serial communication. According to real time sensors values continuous graph is display on PC and Android Based mobile using Internet and Android application. Here threshold value is keep, if sensor values cross the threshold value then Drip Irrigation components can be control automatically by micro-controller. User can also control Drip Irrigation from anywhere via Android mobile [4]. In the Micro-controller based drip irrigation mechanism, this is a real time feedback control system for

monitoring and controlling all the activities of drip irrigation system more efficiently. Irrigation system controls valves by using automated controller to turn ON OFF. This allows the farmer to apply the right amount of water at the right time, regardless of the availability of the labour to turn valves or motor ON OFF. This reduces run-off over watering saturated soils avoid irrigating at the wrong time of the day. It improves crop performances and help in time saving in all the aspects [5]. The management of this kind of farms requires data acquisition in each greenhouse and their transfer to a control unit which is usually located in a control room, separated from the production area. At present, the data transfer between the greenhouses and the control system is mainly provided by a suitable wired communication system, such as a field bus. In such contexts, even though the replacement of the wired system with a fully wireless one can appear very attractive, a fully wireless system can introduce some disadvantages. A solution based on a hybrid wired/wireless network, where Controller Area Network and ZigBee protocols are used. In particular, in order to integrate at the Data Link Layer the wireless section with the wired one, a suitable multi-protocol bridge has been implemented. Moreover, at the Application Layer, porting of Smart Distributed System services on ZigBee, called ZSDS, allows one to access the network resources independently from the network segment [6]. The some system highlights the development of temperature and soil moisture sensor that can be placed on suitable locations on field for monitoring of temperature and moisture of soil, the two parameters to which the crops are susceptible. The sensing system is based on a feedback control mechanism with a centralized control unit which regulates the flow of water on to the field in the real time based on the instantaneous temperature and moisture values [7]. Some system presents Artificial Neural Network (ANN) based intelligent control system for effective irrigation scheduling. The proposed Artificial Neural Network (ANN) based controller was prototyped using MATLAB. The input parameters like air temperature, soil moisture, radiations and humidity are modelled. Then using appropriate method, ecological conditions, evapotranspiration and type of crop, the amount of water needed for irrigation was estimated and then associated results are simulated [8]

### III. AN OVERVIEW ON IRRIGATION SYSTEM USING WIRELESS SENSOR NETWORK AND GPRS

The proposed system has two main units one is wireless sensor unit (WSU) and another is Wireless information unit (WIU). Wireless sensor unit is nothing but transmission section which Transmit the sensor data to the wireless information unit. Wireless information unit is nothing but section which receives sensor data from wireless sensor unit.

#### A. WIRELESS SENSOR UNIT

A WSU is comprised of a RF transceiver, different sensors, a micro-controller, ZigBee and power sources.

Several WSUs can be deployed in-field to configure a distributed sensor network for the automated irrigation system. Each unit is based on the micro-controller that controls the radio modem ZigBee and processes information from the soil-moisture sensor, temperature sensor and water level sensor.

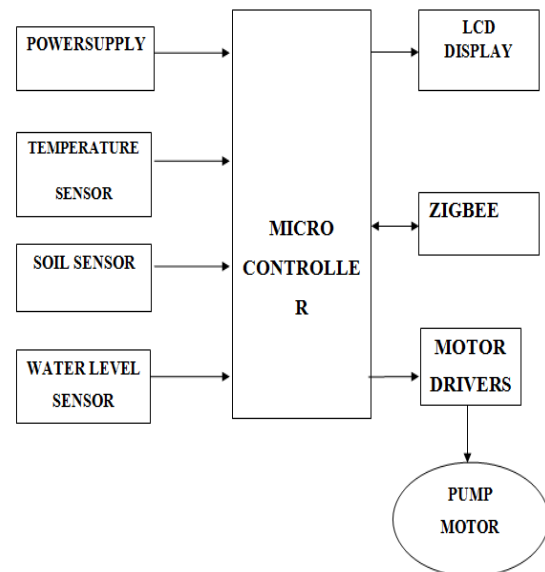

Fig 1. Wireless Sensor Unit

In this wireless sensor unit or transmission unit the sensor data from different sensors (Soil moisture, temperature, humidity and water level) are collected in the main controller. This data is displayed on transmission section LCD.

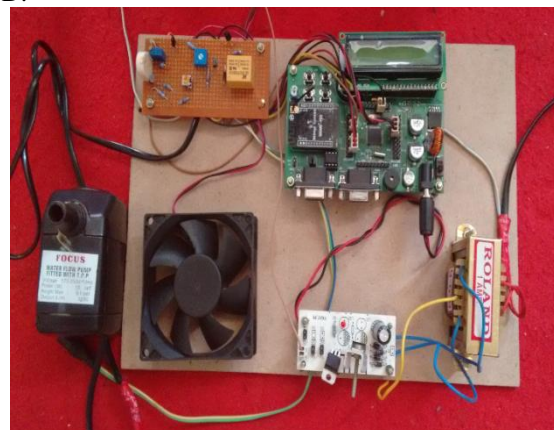

Fig 2. Transmission Section

ARM controller is programmed to some threshold values of temperature and soil moisture. Sensed values are compared with the threshold values and according to comparison automation is takes place.

#### B. WIRELESS INFORMATION UNIT

The soil moisture, temperature and water level sensor data from each WSU are received, identified, recorded, and analysed in the WIU. The WIU consists of a master micro-controller, an ZigBee radio modem, a GPRS module This processed information is send to web page where status of all these sensors are display graphically using graphical

user interface using the GPRS module. The data from the transmission section is received by ZigBee communication modem.

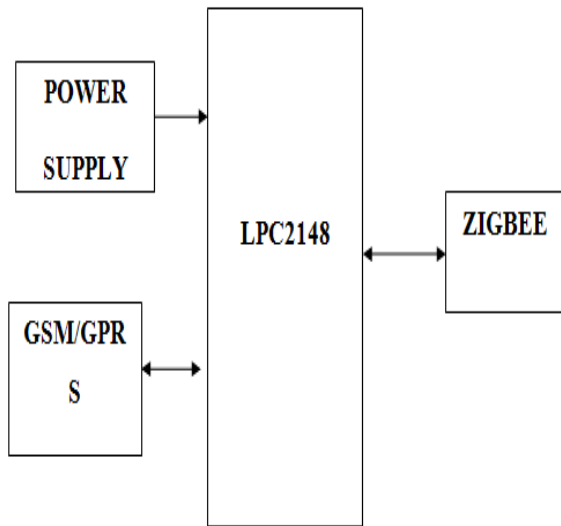

Fig 3. Wireless Information Unit

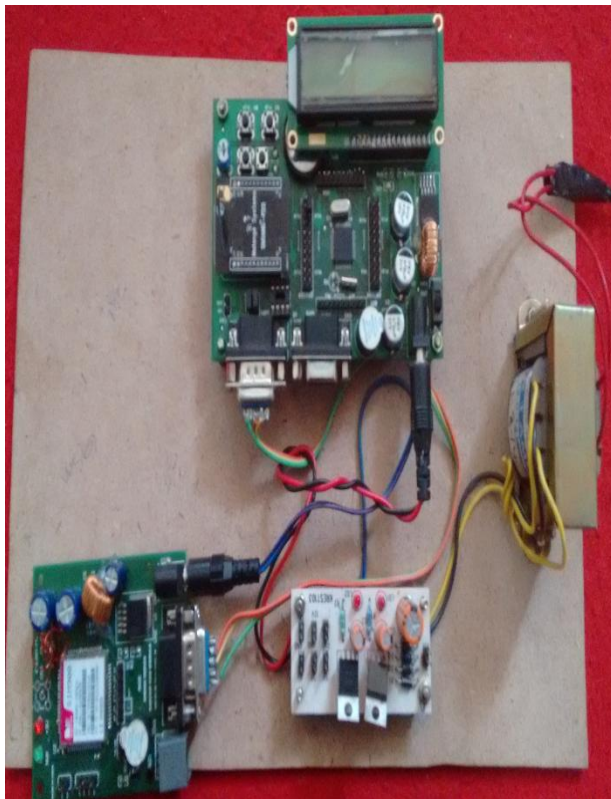

Fig 4. Receiver Section

#### IV. EXPERIMENTATION AND RESULTS

When soil moisture value is less than the threshold value then the motor is start automatically but at that time water level is also checked. As there is no water in tank then motor remains off. There are different conditions for the automation of the irrigation system depends on the sensor values and these conditions are given in Table1 and Table2.

**Table: 1**

Temperature Value	FAN
Less than Threshold	OFF
More than Threshold	ON

**Table: 2**

Different conditions for irrigation system operation

Condi-tion	Soil Moisture	Water level	Motor Status
1	DRY	FULL	ON
2	WET	FULL	OFF
3	DRY	MEDIUM	ON
4	WET	MEDIUM	OFF
5	DRY	LOW	ON
6	WET	LOW	OFF
7	DRY	NULL	OFF
8	WET	NULL	OFF

#### A. Status of Field on Web Page:

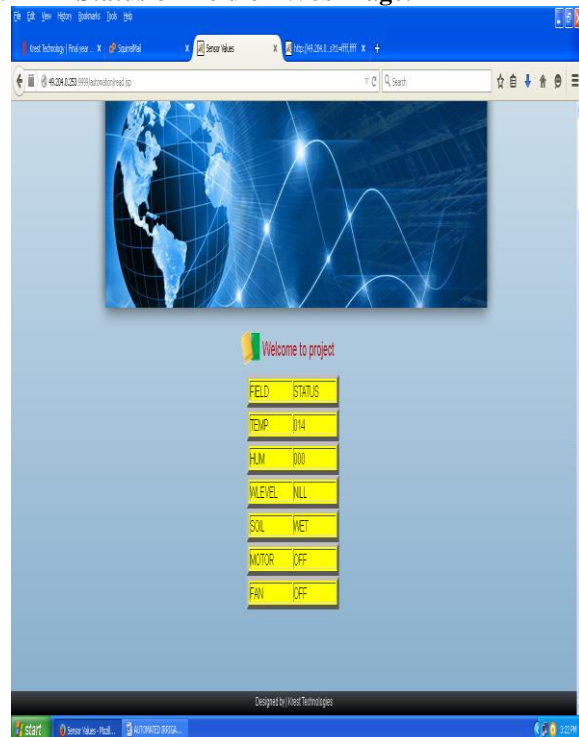

Fig 5. Output of Condition no-8

In the above Web page gives the status of the field for condition number8 in the table2, in that we can monitor the different parameters like the temperature, humidity, water-level, ON/OFF condition of the Motor and Fan.

#### B. Status of Field on Web Page:

This Web page gives the status of the field for condition in that there is low moisture in soil but motor remains OFF because the insufficient water in tank or NULL water level. In this condition the temperature of the field is more than that of the threshold value so FAN is in ON condition.

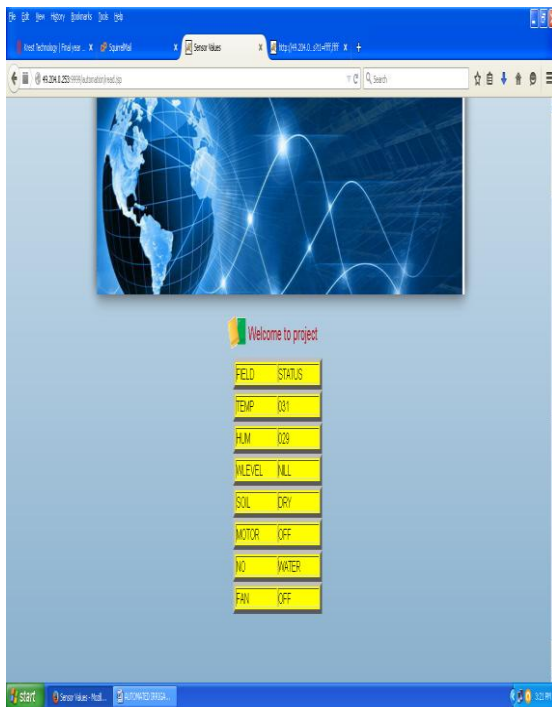

Fig 6. Output of condition no-5

## V. CONCLUSION

1. This system is reduces the water use because it provide irrigation as per the requirement of the crop.
2. This system is automated irrigation system so it reduces the human resources.
3. This irrigation system was found to be feasible and cost effective for optimizing water resources for agricultural production.
4. The irrigation system can be adjusted to a variety of specific crop needs and requires minimum maintenance.

Using this system we can monitor the status of all the sensors (Soil-moisture, Temperature, Water level) and also the ON/OFF status of the motor and Fan.

## REFERENCES

- [1]. Joaquin Gutierrez, Juan Francisco Villa-Medina, Alejandra Nieto-Garibay, And Miguel Angel Porta-Gndara, "Automated Irrigation System Using A Wireless Sensor Network And Gprs Module", Ieee Transactions On Instrumentation And Measurement, Vol. 63, No. 1, January 2014.
- [2]. Vimal.P, Priyanka.V, Rajyasree.M, SanthiyaDevi.P.T, Jagadeeshraja.M, SuthanthiraVanitha.N, "A Novel Approach For Automatic Irrigation And Fertigation Using Embedded System," International Journal Of Vlsi And Embedded Systems-Ijves Vol 05, Article 03257; March 2014.
- [3]. Sathiyabama P, Lakshmi Priya C, Ramesh Sm, Preethi B, Mohanaarasi M, "Embedded System Design For Irrigating Field With Different Crops Using Soil Moisture Sensor," International Journal Of Innovative Research In Computer And Communication Engineering Vol. 2, Issue 8, August 2014.
- [4]. Liai Gao, Meng Zhang, Geng Chen, "An Intelligent Irrigation System Based On Wireless Sensor Network And Fuzzy Control," Journal Of Networks, Vol. 8, No. 5, May 2013.
- [5]. K.Prathyusha, M. Chaitanya Suman, "Design Of Embedded Systems for the Automation Of Drip Irrigation," International Journal Of Application Or Innovation In Engineering Management (Ijaiem) Volume 1, Issue 2, October 2012.
- [6]. ] Orazio Mirabella, Senior Member, Ieee, And Michele Brischetto, "A Hybrid Wired/Wireless Networking Infrastructure

- For Greenhouse Management," Ieee Transactions On Instrumentation And Measurement, Vol. 60, No. 2, February 2011.
- [7]. B.Sivakumar, P.Gunasekaran, T.Selvaprabhu, P.Kumaran, D.Anandan, "The Application of Wireless Sensor Network in the Irrigation Area Automatic System", Ijcta Jan-Feb 2012.
  - [8]. S.Muhammad Umair, R. Usman, "Automation Of Irrigation System Using Ann Based Controller," International Journal Of Electrical Computer Sciences Ijecs-Ijens Vol:10 No:02.May 2010.