

Design and Development of a Portable ECG Acquisition System

K.Anuradha¹, M.Saravanan²

PG Scholar, SNS College of Technology, Coimbatore¹

AP, ECE, SNS College of Technology, Coimbatore²

Abstract: ECG, electrocardiogram plays a major role in detection of heart diseases. The main aim of the processing have been developed each of which overcomes the previous technology by means of reliability. PDAs can be designed by the wireless technology ,due to which remote monitoring is possible. The system thus provides remote monitoring of patients wearing a portable device with wireless connectivity which is based on different technologies such as Bluetooth and WIFI .It is highly cost efficient technology with lesser utilization of power and area. Thus a highly accurate architecture is presented.

Keywords: PDAs, real-time, Pulse Rate, Wireless, WIFI.

INTRODUCTION

In recent years, major advances have occurred in the field of communications which has lead to the technology of packet data transmission services over mobile systems, giving a high support for the development of newer applications. At the same time, the spectacular rise of the number of the subscribers of the mobile telephony systems have sponsored the existence of a wide range of handsets which are wireless. The popularization of such compatible devices has led to a growing interest in order to continuously improve their current features and performance characteristics, and thus an increase in effort of designing have been observed to the development of a low power and higher performance architecture of embedded microprocessors with multiple capabilities. Similarly, a significant enhancement has been done towards the developmental tools and the software support for the corresponding platforms has been achieved. As a result, the Smart phones deliver the capabilities comparable to those displayed by desktop computers only few years ago, including features like the wireless Internet access and support to multimedia, are available nowadays. These handheld portable devices are supported by an operating system to access application software, making it convenient for the development and integration of a third-party software. Initial healthcare systems were designed generally designed for the hospital applications. The healthcare systems are taking a huge turn due to the raising healthcare costs, haphazard lifestyles, increase in population, and growing economy. thus there is a need for improvised changes in how health care should be provided, by keeping in target the preventive care, and effective provision of continuous treatment, with personalized and connected health . Nowadays cardiac healthcare is the fastest growing field of research andworry , as the cardiovascular diseases are one of the major leading causes of death in the world. Out the various medical and healthcare information sources, electrocardiogram(ECG) is best way for measuring and

check the different problems in the functioning of heart. Since the measuring is done by externally placing the electrodes on body; it is painless, inexpensive and measuring quantity due to which it has th become most vital in the area of healthcare and diagnosis. The ECG machine has a history which is vast that has lead to its prominent visible future in medical science. In the year 1856, Mueller led the discovery of the electrical activity of the heart that is, repolarisation and depolarization due to the difference in the electric potentials of cells in heart muscles. Scientist Alexander Muirhead has attached the wires to a feverish patient's wrist in order to obtain a record of the heart beat of patient while he was studying for the D.Sc (in electricity) in 1872, using a Lippmann capillary electrometer which was fixed to a projector. The trace from the recorded heartbeat was projected on a photographic plate which was fixed to a toy train. In 1903, the first practical electrocardiogram was recorded by Holland physiologist.

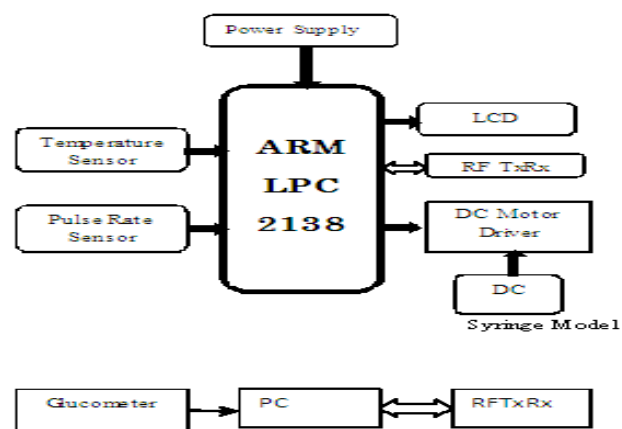

Fig 1:Conventional ECG Acquisition

I.CONTROLLER AND WIRELESS UNIT

As mentioned previously , the process of intercommunication is done through a TCP/IP interface

protocol. Data privacy is a major issue in telemedicine systems, and must be taken care when the data is sent through a wide area network. No mechanisms for encryption has been included in the referred application prototype, but it can be achieved easily by means of the SSH tunnels and virtual private networks (VPN) like applications, both of which are supported by Linux operating system(OS). The different application modules which are described in the previous sections has been developed as well as tested on a particular testing bed. However, it is highly expected to be portable to other platforms and thus adaptable to different scenarios. This section provides the summary of the reference framework onto which the application has been tested and the ARM7 processor provided by the Atmel is a 32 bit processor which is particularly used for mobile and low power device applications. The second one is MSP430 which is provided by Texas Instruments. It is a 16 bit microcontroller, and can be widely used for low power and the biomedical applications.

II.DISPLAY SECTION

The display units are used in analysing the acquired waveform. During olden days a CRO was used in the analysis of the ECG waveform, but nowadays ECG waveforms are printed on graph papers. Also due to the advancement in modern technologies ECG waveform which is obtained from patient's body are directly displayed on the PCs, the LCD monitors and on the PDAs, also these PCs are provided with software that is too fast in the extraction of the different components of waveform. This software has the ability of doing high amount of signal processing in order to reduce the burden on humans and also to produce the results which can be easily interpreted by the specialist. Thus there are two options to transfer the obtained ECG to a PC, one is the wired option i-e; through a serial port and other is via a wireless (Bluetooth). The microcontroller unit is thus connected with the PC or LCD monitor by a serial communication port so as to display the results on it. Special types of hardware is being developed by a no. of companies as such the Texas Instruments, Analog Devices and many more for performing signal processing. With the development of information technology, microelectronics and the communication technology, low power microprocessors, more efficient signal processors and obviously an efficient software platform/tool to analyse the results should be developed.

PROPOSED SYSTEM

In the Proposed method we use a architecture that is compatible with the digital CMOS technology and thus is capable of operating with a lower supply voltage.

The acquisition server module is thus a process which is running in every PDA device, and is in charge of configuration of the acquisition hardware for the analog signal conditioning and the digitization process. This module performs alike operation in response to the requests sent by the client application through a socket

interface. By making use of this socket the server can also transmit to the clients the samples which are acquired from the signal in real time processing. The server module can thus handle two different request groups: configuration commands which is used to setup the acquisition, i.e., the sampling period, number of analog channels, gain, single-encoder differential input, etc and the operation commands

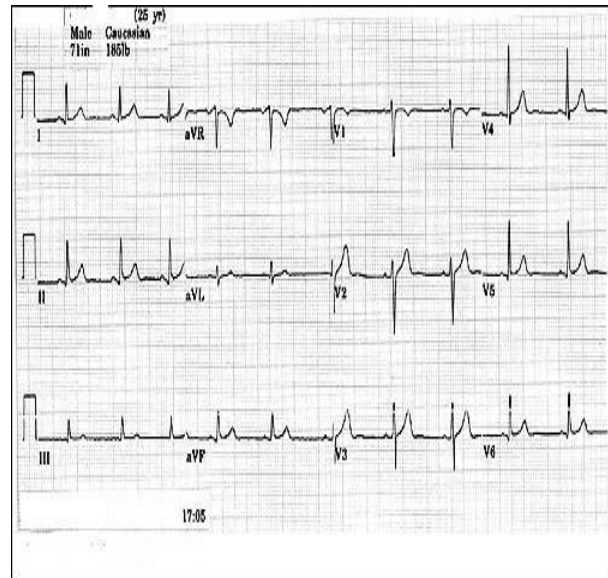

Fig 2: ECG Display

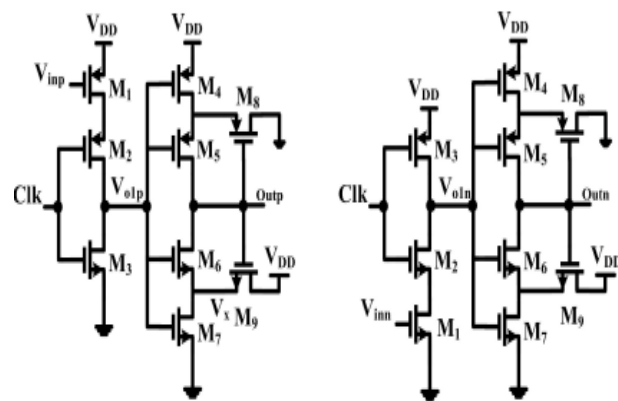

Fig 3: Modified CMOS Architecture For ECG

CONCLUSION

Wireless patient monitoring with the body sensor networking is thus an effective solution for the monitoring of remote patients. As this reduces the cost as well as times of both the doctor and the patient. At a single time doctor can monitor and track the bodily activity of multiple patients. The different body sensors thus continuously collect the body parameters and transfer details to the doctor. In this way the quality of treatment also gets improvised. Thus quality results are provided to increase the speed and accuracy.

REFERENCES

1. Maryam zare ,muhammed maymande-nejas, "A fully digital architecture for ECG acquisition system with 0.5 v support", IEEE J. c Solid-State Circuits vol. 44, no. 4, pp. 1067-1077, Jan 2015.

2. R.Rison and C. Charles, "A low-power low-noise CMOS amplifier for neural recording applications," *IEEE J. Solid-State Circuits*, vol. 38, no. 6, pp. 958–965, Jun. 2011.
3. H. Rezaee-Dehsorkh, N. Ravanshad, R. Lotfi, K. Mafinezhad, and A. M. Sodagar, "Analysis and design of tunable amplifiers for implantable neural recording applications," *IEEE J. Emerg. Sel. Topics Circuits Syst*, vol. 1, no. 4, pp. 546–556, Dec. 2009.
4. M. S. J. Steyaert and W. M. C. Sansen, "A micropower low-noise monolithic instrumentation amplifier for medical purposes," *IEEE J. Solid-State Circuits*, vol. 22, no. 6, pp. 1163–1168, Dec. 2007.
6. W. Wattanapanitch, M. Fee, and R. Sarpeshkar, "An energy-efficient micropower neural recording amplifier," *IEEE Trans. Biomed. Circuits Syst.*, vol. 1, no. 2, pp. 136–147, Jun. 2007.
7. T. Denison, K. Consoer, A. Kelly, A. Hachenburg, and W. Santa, "A 2.2 μ W 94 nV/ $\sqrt{\text{Hz}}$ chopper-stabilized instrumentation amplifier for EEG detection in chronic implants," in *IEEE Int. Solid-State Circuits Conf., Dig. Tech. Papers (ISSCC)*, 2007, pp. 162–594, Dec. 2005.
8. R. Muller, S. Gambini and J.M. Rabaey, "A 0.013mm square, 5 μ W, DC-coupled neural acquisition system," *IEEE J. Solid State Circuits*, vol. 47, no. 1, pp. 232–243, Jan. 2004.
9. M. Fernandez and R. Pallas-Areny, "A simple active electrode for power line interference reduction in high resolution biopotential measurements," *IEEE J. Solid State Circuits*, vol. 1, no. 4, pp. 97–98, Oct. 2002.
10. J.L. Bohorquez, M. Yip, A.P. Chandrashekar, and J.L. Dawson, "A biomedical sensor interface with a sinc filter and interference cancellation," *IEEE J. Solid State Circuits*, vol. 46, no. 4, pp. 746–756, Oct/Nov 1996.
11. P.K. Chan and J. Chui, "Design of chopper based amplifiers with reduced offset for sensor amplification," *IEEE J. Solid State Circuits*, vol. 8, no. 12, pp. 1968–1980, Dec. 2008.