

Advent for Detection of Movement using Raspberry Pi by an Internet of Things: A Survey

Usha K¹, Dr.S.Ambareesh²

PG Scholar, Department of CSE, Vemana IT, Bengaluru, India¹

Associate Professor, Department of CSE, Vemana IT, Bengaluru, India²

Abstract: Internet of things is the interchange of anything with any other thing, the interchange mainly fetch of useable data, like a sensor in a room to observe and control the temperature. the home environment has seen a rapid introduction of network enabled digital technology. It is estimated that by 2020 there will be 50 billion internet-enabled tools. This paper aims to outline a security alarm system using low processing power chips using Internet of things which helps to observe and get alarms when motion is detected and convey photos and videos to a cloud server. Also, internet of things based application can be used remotely to view the agitation and get notifications when movement is detected. The photos and videos are sent directly to a cloud server, when the cloud is not available then the data is stored locally on the Raspberry Pi and sent when the connection restarts. Hence, advantages like these make this application ideal for monitoring homes in absence.

Keywords: Internet of Things, detection of movement, cloud, tools, environment, internet.

INTRODUCTION

Internet of Things (IOT) is an going progress of the Internet by which everyday 'things' objects have communication capabilities which allow them to send and receive data. There was a need to automate home so that users can take advantage of the technological advancement in such a way that a person can send a control signal to the home control center when he forget to turn off devices such as air conditioner instead of returning home[1]. Environment that improves the quality of the resident's life by facilitating a flexible, comfortable, healthy, and safe environment [5]. It is expected to connect systems, devices, sensors which can communicate without the need of machine-to-machine communication. IOT refers to an enormous variety of devices such as sensors that assist fire fighters in rescue and search operations, heart beat and blood pressure measuring devices, bio-chips that are implanted in farm animals. It is expected that by 2020, 20 billion devices will be connected with the Internet. The Internet of things presently is being used in the fields of automobiles, agriculture, security surveillance, building management, smart-homes, and health care. The IOT expects to use low-cost computing devices where there is less energy consumption and limited impact to the environment.

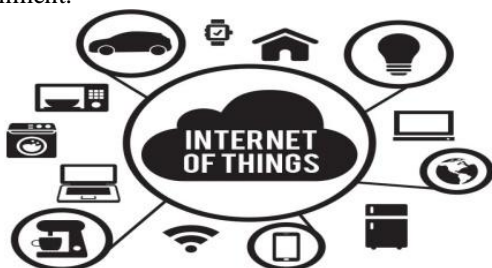

Fig. 1. Internet of Things

The main limitation of Internet of things is that as the devices have limited computing power the security aspects come in question as the transmitted and received data cannot be encrypted and decrypted. However, Internet of things offers many advantages that overcome this disadvantage. The IOT will revolutionize everyday life and help in situations like managing airports' passenger flows, smart homes, heating buildings, caring for the elderly. In the present world where we live there are already devices, which are connected to each other and help in day to day aspects, for example wearable fitness devices, sensors which help in automatic garages, RFIDs in ID cards used in Universities and Industries to gain and lock access. However, imagine this after a few years where billions of devices will be connected to each other including cars, phones, jet planes, appliances, wearable gear etc.

The IOT has its own challenges, which need to be addressed. Every device will require an IP address to communicate, the present IPv4 has only 4.3 billion unique addresses, which will be exhausted soon and hence we will need to adapt to IPv6. The next challenge would be data storage, as billions of devices are connecting the data would need to be stored for which massive storage space is required. After the data have been collected we need to make sure that the security policies are in place as more and more personal information will be collected from devices which not get breached and the data should not get in the hands of hackers. Privacy would also be a great challenge as after the recent hacks people are becoming more concerned about their privacy. Hence these challenges need to be taken in careful consideration before planning any project related to the IOT. In this project of

motion detection these security challenges have been considered after which a successful implementation has been tested.

NEED FOR PROJECT

Incorporating IOT in our lives has many advantages helping individuals, businesses and on everyday basis. Health, safety, security are some forms in which new concepts are emerging in IoT. It can be very beneficial to integrate IOT into security systems and this project aims to integrate IOT in security systems to detect motion, for example everyday when you are at work you will be able to monitor and get notifications if any activity happens at your home. The other major advantage that this system will have over the others is that it will make the users system lightweight for example at present these are possible but not without machine-to-machine communication. In this case there is no need to have machines at both ends to get the desired output. Thus for home users this system will prove to be of great use as it has low energy consumption and also comes at a low cost. The project aims to simplify motion detection and the interface to be user friendly, which would send prompt notifications when motion is detected.

MOTION DETECTION

The primary functions of our project are: Detect Motion. In this a python script would analyze the video, if there is a difference from the last frame it would be flagged and video recording and snapshots generation will begin. Customize Attributes: The user will have the capability to customize the settings for frames per second, resolution, brightness, contrast, saturation etc. On Motion Detected:

The user has the option of customizing the action when motion is detected, for example the option used when testing the project was a script, that was executed on the Raspberry Pi to send an email, hence as the motion was detected the end user received an email and he could do the needful, for example login to the camera and see the movement. On Picture/Movie Save: The user has the option that when a snapshot/video is saved, by default it is saved locally but the user can customize to send it to a ftp server or sftp server or cloud managed service such as Drop box, which supports command line Linux based commands. The pictures/videos are saved instantly if there is a breach in the house and the person tries to remove the setup still the pictures/videos would have already been stored to an external server as configured.

RASPBERRY PI -AN INTRODUCTION Raspberry Pi

It is credit card sized computer, which can plug into any HDMI input device or RCA video input device and a keyboard is required for operation. Once it is initialized the HDMI and keyboard are also not required for its operation as you can then operate it by other means such as ssh for command line interface and VN C if graphical user interface is desired. The main technical specifications of the latest model of Raspberry Pi also known as Model B have the following features:

- 700 MHz ARM CPU
- 512MB SDRAM
- 10/100 Ethernet RJ45
- 2 x USB 2.0
- HDMI (1.4) and Composite RCA

The Raspberry Pi runs Linux based operating systems and there is a specialized version of Linux based kernel known as Raspian which can run almost all programs which are Linux compatible. Hence in this project we have used 'python' and 'wput', script written in python for motion detection and wput for storing the files on an external server. Wireless Browser Based Device Control Using Raspberry Pi: We can observe this research paper that the appliances controlling through the web browser integrated with the ARM11 microcontroller.

The Raspberry Pi is a credit-card-sized single-board computer developed in the UK by the Raspberry Pi Foundation with the intention of promoting the teaching of basic computer science in schools. The Raspberry Pi has a Broadcom BCM2835 system on a chip, which includes an ARM1176JZF-S 700 MHz, Video Core IV GPU, and was originally shipped with 256 megabytes of RAM, later upgraded to 512 MB. It does not include a built-in hard disk or solid-state drive, but uses an SD card for booting and long term storage. In this system, we use the raspberry Pi model as a controller. The Raspberry is a credit card sized minicomputer. There are different types of raspberry pi model available in the market, Such as Model A, Model B, Model B+ out of which we uses Model B+.

PROJECT ARCHITECTURE

This project uses a triple-layered architecture. The first layer is the motion detection layer, which is the outcome by the python script and then in the second layer the actions are triggered as per the configuration file. In the third layer the actions triggered are executed for example sending email to the user or saving the pictures/videos to the ftp/sftp server.

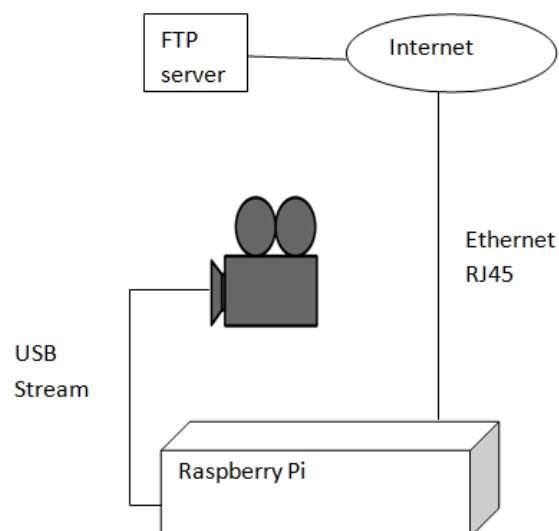

Fig. 2. Project Architecture

The important components of the project are described as below:

1. A script to detect motion. In this project a python script has been used.
2. Python compiler to handle the request.
3. Storage to store the temporary files.
4. Notification methods such as email scripts used in this project.
5. External server to store files, ftp server used in this project.

USE OF PROJECT

The purpose of the project is to make a system, which would detect and take snapshots and videos of the motion when detected and upload to an external server. The major use of the 'Motion Detection' is at homes, buildings and also for surveillance for security for example of server rooms. This equipment when made on a large scale would be much cheaper and would cost under 60\$ which is relatively very cheap to current products which have similar capabilities. The notification can also be done via text messages on mobiles using a text gateway on the Raspberry Pi. The options are unlimited for notification and storage of the files depending on the user's requirements, presently almost everyone has an Internet connection at home and all the members in the family are away during the day, as security systems are not affordable this system would be great alternative to implement.

CONCLUSION

Henceforth, by enhancing the capabilities of these technologies and integrating them, we hope to introduce the 'Motion Detection' system and to contribute to the current security system. This system would be an alternative for expensive security systems being used in the present day. This system does not require any special modifications to the infrastructure where installation is required and can be implemented without any hassle. I have tested this system for 180 days and have found 99.9% accurate notifications and results.

REFERENCES

- [1] Raspberry Pi and Wifi Based Home Automation International Journal of Engineering Research and Applications (IJERA) ISSN: 2248-9622 NATIONAL CONFERENCE on Developments, Advances & Trends in Engineering Sciences (NCDATES- 09th & 10th January 2015)
- [2] Home automation using Raspberry Pi International Journal of Innovative and Emerging Research in Engineering Volume 2, Issue 3, 2015
- [3] RASPBERRY PI HOME AUTOMATION WITH WIRELESS SENSORS USING SMART PHONE P Bhaskar Rao et al, International Journal of Computer Science and Mobile Computing, Vol.4 Issue.5, May- 2015, pg. 797-803
- [4] Design and Implementation of a WiFi Based Home Automation System International Science Index Vol:6, No:8, 2012 waset.org/Publication/5037
- [5] <http://ijcat.org/IJCAT-2014/1-1/Android-Based-Home-Automation-Using-Raspberry-Pi.pdf> IJCAT - International Journal of Computing and Technology Volume 1, Issue 1, February 2014 www.IJCAT.org

- [6] C. Pfister, Getting Started with the Internet of Things. Sebastopol, CA: O'Reilly Media Inc., 2011.
- [7] M. Roelands et al., "Enabling the masses to become creative in smart spaces", in Architecting the Internet of Things, Berlin, Germany: Springer-Verlag, 2011, pp 38-43.
- [8] ZhuanKun Wu. : Initial Study on IOT Security architecture. 1. Strategy and decision-making research (2010)
- [9] Huansheng Ning, Hong Liu. Cyber-Physical-Social Based Security Architecture for Future Internet of Things. J. Scientific research, (2):1-7 (2012)
- [10] Xueguang Yang, Fengjiao Li, Xiangyong Mu, etc.: Design of security and defense system for home based on Internet of things. J. computer application. 30(12):300-318 (2010)
- [11] A N. Ansari, S.Patil, ANavada, APeshave, Y.Borole, Online C/C++ Compiler using Cloud Computing II , Multimedia Technology (ICMT), July 2011 International Conference, pp. 3591-3594.
- [12] Raspberry Pi Org. Forum [Online]. Available: <http://www.raspberrypi.org/phpBB3/>
- [13] L. You-guo and I. Ming-fu, 'The Reinforcement of Communication Security of the Internet of Things in the Field of Intelligent Home through the Use of Middleware', 2011 Fourth International Symposium on Knowledge Acquisition and Modeling, 2011.
- [14] M. Koster. Tools for the open source Internet of things [Online]. Available: <http://iot-toolkit.com>
- [15] Lu Tan and Neng Wang, 'Future internet: The Internet of Things', 2010 3rd International Conference on Advanced Computer Theory and Engineering (ICACTE), 2010.
- [16] L. Atzori, A Iera, and G. Morabito, "The internet of things: A survey," Computer Networks, vol. 54, no. 15, pp. 2787-2805, 2010.
- [17] Innovative Information Science & Technology Research Group, 'Innovative Information Science & Technology Research Group', 2014. [Online]. Available: <http://isyou.info>. [Accessed: 23- Jun-2014].
- [18] Haitao Liu. The Internet of Things Makes Life Better-a Visit of Haitao Hu, the Engineering Technology R&D Center Director of Chinese Academy of Sciences, Wuxi Sensor Network L. Shanghai standardization, 2010. 1.
- [19] D.Guinard, V.Trifa, E.Wilde, "A resource oriented architecture for the web of things", in Proc. Of the Internet of Things (IOT 2010). SAP res., ETH Zurich, Zurich, Switzerland, 2010.
- [20] D. Chen, G. Chang, L. Jin, X. Ren, I. Li and F. Li, 'A Novel Secure Architecture for the Internet of Things', 2011 Fifth International Conference on Genetic and Evolutionary Computing, 2011.
- [21] Z. Yu and W. Tie-Ning, 'Research on the Visualization of Equipment Support Based on the Technology of Internet of Things', 2012 Second International Conference on Instrumentation, Measurement, Computer, Communication and Control, 2012.
- [22] INFISO 0.4 Networked Enterprise&Rfid, INFISO g. 2 Micro&Nano Systems, working group Rfid of the ETPEPOSS, "Internet of Things in 2020 -- Roadmap for the future", 2008