

Monitoring and Controlling of Environmental Parameters Using Embedded Web Server

Ashwini .S. Malewar¹, Prof. Shaila Kharde², Prof. Sonali Chincholikar³

PG Student, ETC, SYCET, Aurangabad, India ¹

Asst. Prof, ETC, SYCET, Aurangabad, India^{2,3}

Abstract: The paper presents the design of embedded web server based on ARM7 processor and Ethernet controller IC ENC28J60. Embedded web server acts as data acquisition system which stores the data from various sensors like temperature, moisture and humidity which are connected to the processor. This data can be remotely accessed by the client through Ethernet. Depending on different values of sensor data the parameters like temperature, moisture and humidity can be controlled through end devices connected to the processor via relays.

Keywords: Embedded web server, ARM 7 processor, Ethernet controller IC ENC28J60, TCP/IP protocol, HTTP protocol.

I. INTRODUCTION

In the field of research where plantation under number of experiments is carried out, it is necessary to monitor and control various environmental parameters like temperature, moisture and humidity for proper plantation. For this purpose a data acquisition system with remote accessibility can be used. Embedded web server can be used as a data acquisition system that will store the data and also it will make the data available to the user on a standard browser. Embedded system with transplanted web server can be called as embedded web server. Embedded web server provides access to the end device for the client by uploading the web pages as per the client request. The released web pages provide Client with the real time information and control the end devices without time and space restriction. As compared to PC with internet facility, embedded web server have advantages of small size, low cost, less power consumption, flexible design and easy to implement. Embedded web server is made up of ARM7 processor and Ethernet controller IC ENC28J60. They use TCP/IP and HTTP protocol for the communication. The client needs to enter the appropriate IP address in the web browser, after which predesigned HTML page will be displayed consisting of sensor status information. TCP/IP protocol is used for communication between client and web browser. HTTP protocol is for communication between web server and web browser.

II. SYSTEM ARCHITECTURE

The system can be divided into four parts. The first part consists of sensors, second part is embedded web server, third part is client and fourth part is controlling device. The sensors are used for the monitoring purpose. In this system the sensors used are temperature, Soil moisture and humidity sensor. The data from the sensor are in the form of electrical signals which are converted into digital form by inbuilt ADC of processor and then stored into the embedded web server. Embedded web server is made up of LPC2148 ARM processor and Ethernet controller IC

ENC28J60 which stores the sensor data. ARM Processor have inbuilt SPI module which supports Ethernet communication facility. ENC28J60 IC is connected to the processor via SPI interface and handles all the network protocol requirements. When the client enters the IP address on the web browser, he will be provided with web page from where he will be able to access the sensor data. Depending on the sensor data the end device can be turned ON or OFF via relay for controlling the parameters. The controlling devices like heater or cooler for temperature control and Sprinkler for moisture control can be used. The Block Diagram of System is as in Fig. 1.

III. HARDWARE DESCRIPTION

A. LPC2148

The LPC2148 micro-controllers are based on a 32/16 bit ARM7TDMI-S CPU core. They have real-time emulation and embedded trace support, that combines the micro-controller with embedded high speed flash memory of 512 kb of which 500 kb is used for data and 12 kb is used for software programs. It has 128-bit wide memory interface and a unique accelerator architecture that enables 32-bit Code execution at the maximum clock rate. For critical code size applications, the alternative 16-bit Thumb mode reduces the code by more than 30% with minimal performance penalty. Due to its tiny size and low power consumption, LPC2148 are ideal for various applications. It has serial communications interfaces ranging from a USB 2.0 Full Speed device, multiple UARTS, SPI, and SSP to I2Cs. It has on-chip SRAM of 8 kb up to 40 kb out of which 32 kb is used for data and 8 kb is used for DMA when USB is used. This makes these devices very well suited for communication gateways and protocol converters, soft modems, voice recognition and low end imaging, providing both large buffer size and high processing power. Two 32-bit timers/external event counter, watchdog timer, dual 10-bit ADC(s) which provides a total of 6/14 analog inputs, single 10-bit DAC

which provides variable output, PWM channels and 45 external, two buses Advanced high performance bus fast GPIO lines with up to nine edge or level sensitive (AHB) and VLSI peripheral bus(VPB).

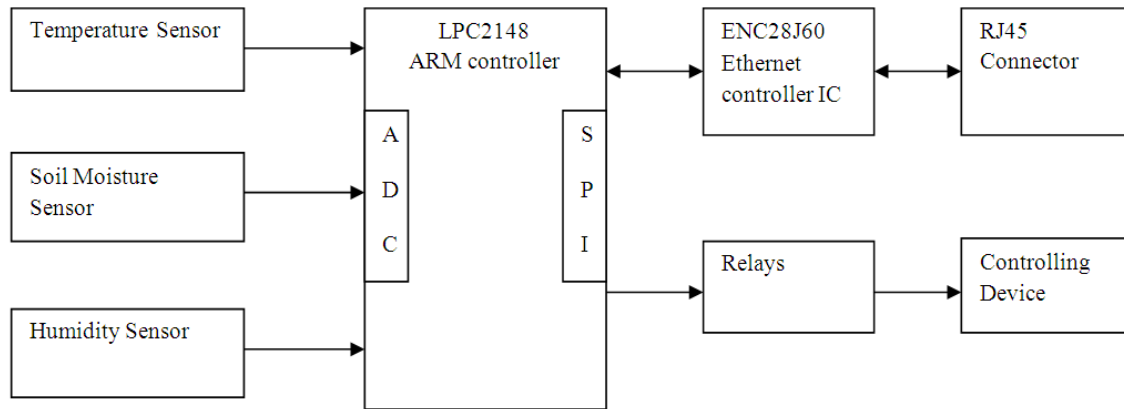

Fig.1 Block Diagram of System

B. ENC28J60

The ENC28J60 is a stand-alone Ethernet controller with a standard Serial Peripheral Interface (SPI). It is designed to serve as an Ethernet network interface for any controller having inbuilt SPI facility. The ENC28J60 meets all of the IEEE 802.3 specifications. Inbuilt it has a number of packet filtering schemes to limit incoming packets. It also has an internal DMA module for fast data processing and hardware assisted checksum calculation, which is used in various network protocols. This controller Communicates with the host controller via an interrupt pin and the SPI, with clock rates of up to 20 MHz's. There are two dedicated pins that are used to indicate LED link and network activity. The ENC28J60 consists of seven major functional blocks:

- a) SPI interface- It serves as a communication channel between the host controller and the ENC28J60.
- b) Control registers- They are used to control and monitor the ENC28J60.
- c) Dual port RAM buffer-Used for received and transmitted data packets.
- d) Arbiter-To control the access to the RAM buffer when requests are made from DMA, transmit and receive blocks.
- e) Bus interface-It interprets data and commands received via the SPI interface.
- f) MAC (Medium Access Control) module- It implements IEEE 802.3 compliant MAC logic.
- g) PHY (Physical Layer) module-It encodes and decodes the analog data that is present on the twisted-pair interface.

C. Sensors

a) Temperature sensor: LM35 IC has been used for sensing the temperature. It is an integrated circuit sensor That can be used to measure temperature with an electrical output proportional to the temperature (in °C). The temperature can be measured more accurately with it than using a thermostat. The sensor circuitry is sealed and not subject to oxidation.

c) Humidity Sensor: The humidity sensor HH10D is used for sensing humidity. Relative humidity is a measure, in percentage, of the vapor in the air compared to the total amount of vapors that could be held in the air at a given temperature.HH10D gives the output in terms of frequency at a range of 5 kHz to 10 kHz from frequency out pin.

IV. SOFTWARE DESCRIPTION

A. Keil ARM

This is a window-based software development platform that combines a robust and modern editor with a project manager and make facility tool. It integrates all the tools needed to develop embedded applications including a C/C++ compiler, macro assembler, linker/locator, and a HEX file generator. The µVision IDE and Debugger is the central part of the Keil development tool chain and has numerous features that help the programmer to develop embedded applications quickly and successfully. The Keil tools are easy to use, and are guaranteed to help you achieve your design goals in a timely manner.

B. Flash Magic

Flash Magic is loaded being performed. This means that other applications that need to use the COM Port, such as debugging tools, may be used while Flash Magic is Windows software from the Embedded Systems Academy that allows easy access to all the ISP features provided by the devices. Flash Magic provides a clear and simple user Under Windows; only one application may have access the COM Port at any one time, preventing other applications from using the COM Port. Flash Magic only obtains access to the selected COM Port when ISP operations are being performed.

This means that other applications that need to use the COM Port, such as debugging tools, may be used while Flash magic is loaded. To download the hex file into microcontroller board we use a programmer called flash magic tool.

V. COMMUNICATION PROTOCOLS

A. TCP/IP Protocol

TCP/IP protocol provides set of rules for end-to-end connectivity which specifying how the data should be packetized, addressed, transmitted, routed and received at the destination. This is done into four abstraction layers which are used to sort all related protocols according to the scope of networking involved. From lowest to highest, the layers are as follows-

- a) Link layer- contains communication methods for data that remains within a single network segment i.e. link.
- b) Internet layer- connects the independent networks and establishes the internetwork.
- c) Transport layer- handles host-to-host communication.
- d) Application layer- it provides process-to-process data exchange for applications.

B. HTTP Protocol

HTTP stands for Hypertext Transfer Protocol and it is the set of rules for transferring the files like text, graphic images, sound, video, and other multimedia files on the World Wide Web. When a web user opens their Web browser, the user is indirectly making use of HTTP. HTTP is nothing but an application protocol that runs on top of the TCP/IP suite of protocols. HTTP follows the idea that the files to be transferred contain the references of other files whose selection will elicit additional transfer request.

machine receives the request and sends back the requested file or files associated with the request.

VI. CONCLUSION

The basic aim of the project is to create an embedded web server that enables the monitoring and controlling of environmental parameters like temperature, moisture and humidity. An embedded web server occupies less space. So there is no need of a fully-fledged computer but requires only just a microprocessor that has an inbuilt TCP/ IP stack with minimum operating system software which is required for networking.

ACKNOWLEDGMENT

I express my sense of gratitude and sincere regards to my guide **Prof. S.P. Kharde** for guiding me properly in my project work and for helping to solve the project work difficulties. I would also like to thanks all the staff members of Electronics and Telecommunication Department for supporting and guiding me in my project wok whenever required.

REFERENCES

- [1] Sushma M. Gawali, Snehal M. Gajabhiye, "A Design of Embedded based Web Server or Monitoring and Controlling Agricultural Field ", International Journal of Current Engineering and Technology Vol.4, issue 1st June 2014.
- [2] Tao Lin, Hai Zhao, Jiyong Wang, Guangjie Han, Jindong Wang, " An Embedded Web Server for Equipments ", Proceedings of the 7th International Symposium on Parallel Architectures, Algorithms and Networks (ISPAN'04), 2004 IEEE.
- [3] B. Srinivas Raja1 and G. Srinivas Babu2 "Design of Web based Remote Embedded Monitoring system", International Journal of Technology and Engineering System (IJTES): Jan –March 2011-Vol.2
- [4] Aami.M Parkar, Prof. S.I.Nipaniakar, "STUDY ANALYSIS OF EMBEDDED WEB SERVER FOR BOILER PARAMETERS", International Journal of Advanced Research in Electronics and Communication Engineering (IJARECE) Volume 4, Issue 7, July 2015.
- [5] Liu Yang, Linying Jiang , Kun Yue ,Heming Pang " Design and Implementation of the Lab Remote Monitoring System Based on Embedded Web Technology", 2010 International Forum on Information Technology and Applications,2010 IEEE.
- [6] ENC28J60 Data sheets, by Microchip Technology Inc.

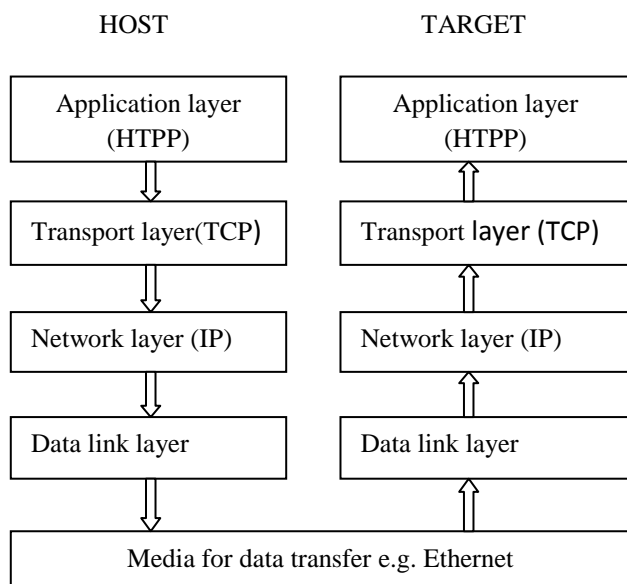

Fig. 2 TCP/IP protocol

In addition to the web page files every web server machine contains an HTTP daemon, which a program that is designed to wait for HTTP requests and handles them when they arrive. Web browser is an HTTP client which sending requests to server machines. When the browser user enters file requests by opening a Web file or by clicking on a hypertext link, the browser builds an HTTP request and sends it to the IP address indicated by the URL. The HTTP daemon in the destination server