

# Optimized Water Controlling Approach for Irrigation System Based on Wireless Sensor Network and GPRS Module

Shweta B. More<sup>1</sup>, Prof. D. L. Bhuyar<sup>2</sup>

Student, Electronics & Tele-communication, CSMSS, Aurangabad, India<sup>1</sup>

Professor, Electronics & Tele-communication, CSMSS, Aurangabad, India<sup>2</sup>

**Abstract:** Agriculture uses most of available fresh water resources and this use of fresh water resources will continue to be increases since population growth and food demand increases. An automated irrigation system mainly designed to optimize the usage of water on agriculture because of climatic conditions which leads to lack of rains. The system has soil moisture wireless network and a wireless sensor to maintain the quality of water in three parameters- pH, conductivity and temperature. Wireless and soil moisture sensor is programmed with microcontroller based gateway which is used to control and maintain the flow and quality of water. The system which is used here is duplex communication link based on a cellular Internet interface. By using this automated system water is saved of up to 92% and produce a good yield compared with old irrigation systems.

**Keywords:** Automation, GPRS Module, Internet, irrigation, measurement, water resources and wireless sensor networks (WSNs).

## 1. INTRODUCTION

Indian economy is basically depends on agriculture. Agriculture mainly depends on fresh water worldwide, and there is increased consumption of water due to over population and demand for food materials. So Agriculture is in need of a best strategy based on science and technology for optimum use of fresh water, including quality improvements.

Many basic and technologically advanced systems are available to achieve water savings in various crop fields. Additionally other systems have been developed based on Crop Water Stress Index (CWSI) to optimize the use of water and irrigation scheduling. An Infrared canopy temperature, ambient air temperature, and atmospheric vapor pressure deficit values used to measure the index value to determine when to irrigate using drip irrigation. For automation of Irrigation systems we can use dielectric moisture sensors to control actuators and save water, and a cheaper wireless sensor to check the quality of water irrigation schedule is determined at what particular time of the day and with a specific duration instead of pre-determined scheduling. When the volumetric level of water is reduced below the set point an irrigation controller is used to open the solenoid valve. The pH level of water is indicated to the user. Knowledge of the soil and crop is important in managing soil pH for best crop performance. Other reports say that automating corn crop irrigation uses infrared thermometers. With a timed temperature threshold, automatic irrigation was triggered once canopy temperatures exceeded the threshold for certain time accumulated per day.

A system has been implemented for malting barley cultivation in large area of land that allows optimized

usage of water to provide a better irrigation system by decision support software and its integration with an infield wireless sensor network (WSN) driving an irrigation machine converted to make sprinkler nozzles controllable. This irrigation system network consisted of mainly 5 sensor stations and a weather station.

Thoroughly monitoring the conditions of crops by means of soil moisture and air, and canopy temperature measurement in cropped fields a data acquisition has been made. Handheld computer are used to download the data through a serial port for analysis and storage. For Internet monitoring of drainage water using distributed passive capillary wick type meters a weather station is set up and another system for checking the effectiveness of water usage is used, When the water flux reached below the root zone under an irrigated cropping system the measurements were taken. There are hybrids architectures, wireless modules are located inside the green-house where great flexibility is required, and wired modules are used in the outside area as actuator controllers. The deployed area requires a considering arrangements, such as terrestrial ground, underwater, multimedia, and mobile to improve the current methods in the above real time of multi range applications of monitoring to support the response appropriately. Wireless embedded sensors and actuators that enable monitoring and control was the combination done.

Appropriate management, such as monitoring of environmental conditions those included weather, soil moisture content, soil temperature, soil fertility, mineral content, and weed disease detection, soil pH range, water quality management, moisture content, observing and

monitoring growth of the crop by automated irrigation facility and storage of agricultural products have been used to provide data used in agricultural applications. The embedded processors to complete and expensive acquisition systems that support diverse sensors and include several communication features exists in various commercial WSN's many low-cost and low-power components have been implemented in both hardware and software with latest electronic designs and operation techniques that have to be implemented for power management which also included ranging from limited and low-resolution devices with sensors . The selection of a microprocessor becomes more important in power related design. The strategy has involved combining it with efficient power management algorithms to optimize battery lifetime by employing energy harvesting mechanism.

For providing multitask support, data delivery and energy efficiency performance it has wireless standards that have been recently developed, IEEE 802.11b (Wi-Fi) and wireless personal area network (WPAN), IEEE 802.15.1 (Bluetooth) , IEEE 802.15.3 (UWB) , and IEEE 802.15.4 (Zigbee) , are some standards of wireless local area network . In this paper, within rural areas the development and deployment of microcontroller based automatic irrigation system on wireless communication is presented. Here, the automated irrigation system is powered by photovoltaic cells, the system consists of soil moisture and temperature sensors through a distributed wireless network is implemented and penerated in plant root zones. The sensor node individually involved probes like soil-moisture probe, temperature probe, a microcontroller for data acquisition, and a radio transceiver for the measurements data of a sensor are transmitted to a microcontroller based receiver. This acts as a gateway when the threshold values of soil moisture and temperature are reached permits the automated activation of irrigation. Through the Zigbee protocol communication is done between sensors and data receivers under the IEEE 802.15.4 WPAN. Using general packet radio service (GPRS) protocol, which is a packet oriented mobile data service used in 2G and 3G cellular global system for mobile. Communications (GSM) based on cellular network and the receiver unit has a duplex communication. For the real time data inspection on a website is allowed by internet connection, where the soil-moisture, pH level, quality of water, temperature levels which are represented graphically through an application interface and then stored in a database server. The irrigation schemes and trigger values which are scheduled and in the receiver according to the growth of crop, type of crop, season management accessed enables the direct programming.

**2. AUTOMATED IRRIGATION SYSTEM**

There are different types of irrigation system a) Surface irrigation b) Localized irrigation c) Drip Irrigation d) Sprinkler irrigation. The irrigational conformist methods like overhead sprinklers, flood type feeding systems

usually wet the lower leaves and stem of the plants but not the entire plant. The entire soil surface is soaked and often stays wet long after irrigation is completed. In Such condition there are chances of promotion of infections by leaf mold fungi. On othe hand the modern type of irrigation method are the drip or trickle irrigation , that slowly applies less amount of water to plant root zone. Water is supplied regularly often daily to preserve constructive soil moisture situation and to avoid condition like moisture stress in the plant with proper use of water resources.

The automated irrigation system shown in figure 1, consisted of two components, wireless sensor units (WSUs) and a wireless information unit (WIU), linked by radio transceivers that allowed the transfer of soil moisture and temperature data, implementing a WSN that uses Zigbee technology. The wireless information unit has also a GPRS module to transmit the data to a web server via the public mobile network. The information can be monitored remotely online through a graphical representational application through Internet access devices.

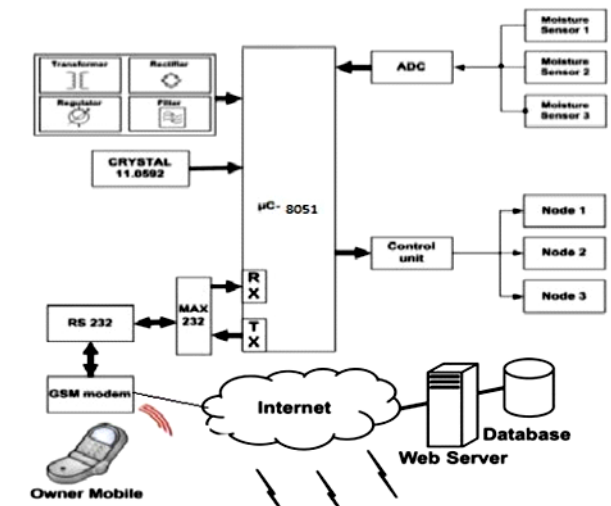

Fig.1. Block diagram for Automatic Irrigation using multi parameter monitoring

**A. Wireless Sensor Unit (WSU)**

A Wireless Sensor Unit consists of a battery, RF transceiver, sensors, a microcontroller, and all together connected to GSM module. In automated irrigation system several WSUs are mainly used to configure distributed sensor network. Then AD Converter is mainly used to get the analog input from sensor and convert it in to digital signals for easy understanding of computers. The digitalized inputs are then passed into 8051 microcontroller. MAX232 performs both sending and receiving operations, RS232 collects the information from the MAX232 and send signal to GSM module which gets transmitted via internet, then stored in database. This operation helps the farmer to check the soil moisture analysis and also about the temperature, pH level of soil. The microcontroller may be programmed in C compiler with the appropriate algorithm for monitoring the soil moisture probe through a port called analog to digital and

another digital port is to measure the soil-temperature, implemented in 1-Wire communication protocol. The RS-232 protocol is used to pack the data with corresponding date, identifier and time to be transmitted via ZigBee radio modem through two digital ports configured as (TX) and (RX), respectively. When the data has been received by the microcontroller it is set in sleep mode for certain period according to the sensor sampling rate desired, whereas the internal RTCC is running.

**1) Zigbee (over IEEE 802.15.4)**

This technology is based on short range wireless sensor network and it was selected mainly because of low cost, minimum power consumption (because of low latency), battery operated sensor network and has a greater use while comparing with other wireless technologies like Wi-Fi (IEEE 802.11), Bluetooth (IEEE 802.15.1) and UWB(802.15.3)[67]. The Zigbee devices supports both star and mesh network and also in generic mesh network which can be categorized by coordinator, end device, router.

Among commercial devices zigbee PRO S2 is an appropriate module to establish communication between WSU and WSI, mainly because of its quality of long-range operation and reliability. The Xbee-PRO S2 is a RF modem with integrated chip antenna, 20-pins, and 13 general purpose input/output (GPIO) ports available of which four are ADC. It can operate up to a distance of 1500 m in outdoor line-of-sight with 170 mA of TX peak current and 45 mA for RX current at 3.3 V and power-down current of 3.5  $\mu$ A.

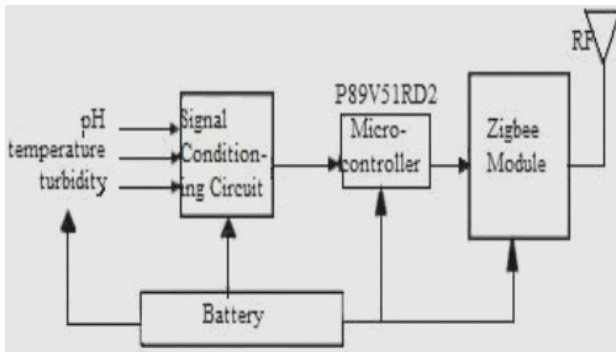

Fig 2 Block diagram of Zigbee based wireless sensor node

General block diagram of Zigbee based WSU is shown in figure 2, Through the serial port microcontroller is interfaced with Xbee radio modem of each WSU is powered at 3.3 V through a voltage regulator ADP122AUJZ-3.3-R7 (Analog Devices, Norwood, MA), a logic-level asynchronous serial, and voltage compatible UART configured at 9600 baud rate, and it has no – parity bit , 1 start bit, 1 stop bit, and 8 data bits. By Using Xbee radio modem of the wireless information unit we can easily deploy the end devices with network topology performing point to-point access.

**2) Sensor Goals**

This module consists of three sensors a) water quality, b) temperature and c) including moisture sensor. For the purpose of low cost and low power VH400 probe is used

to estimate the moisture level (>7mA) this probe is used for measuring for dielectric constant using various transmission line techniques, which is insensitive to water salinity. It provides an output range (0 to 3.0V). According to calibration curve it is proportional to volumetric water content VMC. The sensor was powered at 3.3 V and monitored by the microcontroller through an ADC port products have been used to provide data used in agricultural applications. Digital thermometer DS1822 measures the soil temperature measurements. The sensor converts temperature to a 12-bit digital word and is stored in 2-B temperature registers, corresponding to increments of 0.0625 °C. The temperature is required through a reading command and transmitted using 1-Wire bus protocol implemented in the microcontroller through one digital port. The thermometer has  $\pm 2.0$  °C accuracy over  $-10$  °C to  $+85$  °C temperature range and a unique 64-bit serial number. The sensor is a 3-pin single-chip and TO92 package that was embedded in a metal capsule and sealed in a waterproof PVC cylindrical container.

**3) Photovoltaic Cell:**

To maintain the charge of the WSU batteries, a solar panel MPT4.8-75 was employed. Each solar panel delivers 50 mA at 4.8 V, which is sufficient energy to maintain the voltage of the three rechargeable batteries. A MSS1P2U Schottky diode (Vishay, Shelton, CT) is used to prevent the solar module and to drain the battery when is in the dark. The solar panel is encapsulated in a 3-mm clear polyester film. All the WIU electronic components were encapsulated in a waterproof PVC box as shown in Figs. 5 and 6. The WIU can be located up to 1500-m line-of-sight from the WSUs placed in the field.

**3. PROPOSED METHOD**

**1) Smart water sensor:** The sensor is used to monitor the quality of water. This is comprised of multiple sensors which measure a dozen of most relevant water quality. Wasp mote is the first device which monitors the water quality by interaction with the cloud. This sensor detects the amount of chemical in water (due to use of pesticides), remote measurements of swimming pool, and salt level in sea water.



Fig. 3. Smart sensor board +probe wasp mote ODE

This sensor measures conductivity, oxidation reduction potential, salinity, turbidity, this type of sensor is low power sensor which is equipped in crop fields for checking quality and deployment in cities in hard to access to detect potential risk for the public health real-time. Wasp mote can also use cellular 3G, GPRS, WCDMA and zigbee to

establishing connection in cloud. It reduces the operational costs, accuracy and efficiency. Smart water solution is now available at a price point ten times cheaper than less market solutions. This provides better management of water.

At each predefined time to a web server through HTTP via the GPRS module to be deployed on the Internet web application in real time. When the server receives a request for the web page, it inserts each data to the corresponding field in the database. The WIU includes a function that synchronizes the WSUs at noon for monitoring the status of each WSU. In the case that all WSUs are lost, the system goes automatically to a default irrigation schedule mode. Besides this action, an email is sent to alert the system administrator.

**2) GPRS Module:** The MTSMC-G2-SP is a cellular modem embedded in a 64-pins universal socket that offers standards-based quad-band GSM/GPRS Class 10 performance. This GPRS modem includes an embedded transmission control protocol/Internet protocol stack to bring Internet connectivity, a UFL antenna connector and subscriber identity module (SIM) socket. The module is capable of transfer speeds up to 115.2 K b/s and can be interfaced directly to a UART or microcontroller using AT commands. It also includes an onboard LED to display network status. The GPRS was powered to 5 V regulated by UA7805 (Texas Instruments, Dallas, TX) and operated at 9600 Bd through a serial port of the master microcontroller and connected to a PCB antenna. The power consumption is 0.56 W at 5 V. In each connection, the microcontroller sends AT commands.

**3) Watering Module:** The irrigation is performed by controlling the two pumps through 40-A electromagnetic relays connected with the microcontroller via two optical isolators CPC1004N (Clare, Beverly, MA). The pumps have a power consumption of 48 W each and were fed by a 5000-l water tank.

Four different irrigation actions (IA) are implemented in the WIU algorithm:

- 1) Fix duration for manual irrigation with the push button;
- 2) Schedule date and time irrigations through the web page for any desired time;
- 3) regulate the soil condition and water level, moisture in soil
- 4) send the data through Zigbee *i.e.* WSU to WSI
- 5) Automate irrigation with a fixed duration, if at least one soil moisture sensor value of the WSN drops below the programmed threshold level;

#### 4. CONCLUSION

In this paper we have found cheaper, effective, and feasible by the limited usage of water for agricultural production. The automated irrigation system will prove to be useful and reducing use of water and this will be useful for cultivators to check the level of chemical fertilizers etc. For one of the quality of minimum maintenance, the irrigation system can be adjusted to a variety of specific crop needs. The configuration of the automated irrigation

system allows it to be scaled up for larger greenhouses or open fields. The transmission system *i.e.* Zigbee is found to be cheaper and faster than others. The Internet controlled duplex communication system provides a powerful decision-making device concept for adaptation to several cultivation scenarios. Furthermore, the Internet link allows the supervision through mobile telecommunication devices, such as a smart-phone. Besides the monetary savings in water use, the importance of the preservation of this natural resource justify the use of this kind of irrigation systems.

#### ACKNOWLEDGMENT

I would like to express my gratitude towards my, guide **Prof. D.L. Bhuyar** who is professor at CSMSS, Aurangabad for their time to time help and valuable guidance.

#### REFERENCES

- [1] W. A. Jury and H. J. Vaux, "The emerging global water crisis: Managing scarcity and conflict between water users," *Adv. Agronomy*, vol. 95, pp. 1–76, Sep. 2007.
- [2] X. Wang, W. Yang, A. Wheaton, N. Cooley, and B. Moran, "Efficient registration of optical and IR images for automatic plant water stress assessment," *Comput. Electron. Agricult.*, vol. 74, no. 2, pp. 230–237, Nov. 2010.
- [3] G. Yuan, Y. Luo, X. Sun, and D. Tang, "Evaluation of a crop water stress index for detecting water stress in winter wheat in the North China Plain," *Agricult. Water Manag.*, vol. 64, no. 1, pp. 29–40, Jan. 2004.
- [4] S. B. Idso, R. D. Jackson, P. J. Pinter, Jr., R. J. Reginato, and L. Hatfield, "Normalizing the stress-degree-day parameter for environmental variability," *Agricult. Meteorol.*, vol. 24, pp. 45–55, Jan. 1981.
- [5] H. Y. Erdem, L. Arin, T. Erdem, S. Polat, M. Deveci, H. Okursoy, and T. Gültas, "Crop water stress index for assessing irrigation scheduling of drip irrigated broccoli (*Brassica oleracea* L. var. *italica*)," *Agricult. Water Manag.*, vol. 98, no. 1, pp. 148–156, Dec. 2010.

#### BIOGRAPHIES

**A. Shweta.B. More**, student of M.E (E&TC) 2<sup>nd</sup> Year CSMSS Engineering College, Aurangabad, Maharashtra, India.

**B. Prof.D.L. Bhuyar**, Professor at CSMSS College of Engineering, Aurangabad.