

# Control Strategy for Trajectory Tracking of Robotic Arm

Kiran Kumar Hirwani<sup>1</sup>, Naveen Kumar Dewangan<sup>2</sup>

M Tech Scholar Department of ET&T, Bhilai Institute of Technology, Durg, India<sup>1</sup>

Associate Professor Department of ET&T, Bhilai Institute of Technology, Durg, India<sup>2</sup>

**Abstract:** Today's age is the age of technology and there is very small window for error or it can be said that there is no place for error. When it comes to the robot arm manipulator there is no provision for error and this area increased attention in recent years because dynamic modelling is very advantageous for control strategy of robot arm position. Earlier projects are presented in fuzzy form with MSC ADAMS as modelling tool. Methodology is simple in earlier paper i.e. draw fuzzy rules and manipulate the co-ordinate points for the robotic arm. In this paper ANFIS model is presented and compared with fuzzy based models. ANFIS model is presented to obtain good efficiency and the robustness of proposed control scheme. ANFIS model overcomes the drawback of earlier models.

**Keywords:** ANFIS, MSC ADAMS, Fuzzy, CATIA, MATLAB-Simulink.

## I. INTRODUCTION

Employment of robots in manufacturing has been added entity for the corporate in gaining their benefits. Zomaya [1] describes some options of robots in industry world, which can really attenuate the value of labour and cost of the labour and double the flexibility and versatility and gives higher precision and productivity. These robots replace the human where the hazardous environment is very likely to occur and also in impractical environment and gives better working result than human in that area document is a template. An electronic copy can be downloaded from the conference website. For questions on paper guidelines, please contact the conference publications committee as indicated on the conference website. Information about final paper submission is available from the conference website.

Farrington *et al.*[2] states that robotic simulation is different from traditional discrete event simulation. Robotic simulation covers the visual image of however the mechanism moves through its atmosphere. Basically the simulation is heavily supported CAD, MSC ADAMS and other graphical visual tools. Alternative form of simulation is numerical simulation which deals with dynamics, sensing and management of robots. It has been accepted that the key advantages of simulation is reduction in price and time once coming up with proving system.

The robot manipulators is a multi-articulated mechanical system, in which each articulation is run by an individual electric mechanism i.e. electric actuators is that the most automation industry employed. Many efforts are created in developing management theme to achieve precise tracking control mechanism of robotic arm manipulators.

The PID controller has been used with stable performance and simple structure. But however it is tough to satisfy the high precision and quick response, furthermore the parameters calibration of classical PID controller is

complicated, so for that reason fuzzy algorithm has been introduced.

Fuzzy controller is specific variety of computational intelligence. As far as potential is concerned it has a great potential for uncertain non-linear dynamics to compensate by using the programming capability of human management behaviour. The things which make the fuzzy most effective is that knowledge control base which is in it. The control actions which are generated is the result of by applying the existing conditions or data to the knowledge base [3][4]. Also the data based and inference mechanism will handle no crisp, incomplete information; the data base itself can improve and evolve through learning and past experience [3].

Fuzzy logic technique does not need a standard model of the method, whereas most of the conventional techniques need either an analytical model or an experimental model. Fuzzy logic technique is especially appropriate for complicated and ill-defined process within which analytical modelling is tough owing to the actual fact that the method isn't utterly better known and experimental model identification is not possible as a result of the desired inputs and outputs of the method may not be measurable [4].

The full form of ANFIS is Adaptive Neuro-Fuzzy Inference System was developed by Jang in early 90s. Jang combines the idea and intelligence of fuzzy logic and neural networks to make a hybrid intelligent system that enhances the flexibility to automatically learn and adapt [5].

When it come across the purpose of drawback definition it's very obvious to outline what's the present drawback and what was the past one. It is also important to recognize whether or not the present problem is existing alone or it is influenced by the past one. Because the days

are passing resolution is rising with the assistance of literatures, formulae and statistics. The journey of trajectory point tracking comes to halt or need some additional efforts once there issue of closeness of sampling trajectory point arises as a result of this the trajectory points don't seem to be within the surround of the reference. Then the system or prototype goes to verge of instability or can be the system or prototype becomes unstable.

## II. FUZZY THEORY

### A. Fuzzy Theory

Fuzzy pure mathematics provides a serious newer paradigm in modelling and reasoning with uncertainty. Though there have been many forerunners in science and philosophy, particularly within the areas of multivalued logics and vague ideas, Lotfi A. Zadeh, a professor at University of California at Berkeley was the primary to propose a theory of fuzzy sets and an associated logic, particularly symbolic logic. Basically a fuzzy set could be a set whose members could have degrees of membership between 0 and 1, as against classical sets wherever every part should have either zero or one because the membership degree if zero then the part is totally outside the set; if one then the part is totally in the set. As classical logic relies on classical pure mathematics, symbolic logic relies on fuzzy set theory [6].

### B. Fuzzy Variables, Rules and System

Linguistic variable is outlined by its name, by the realm of verbal values outlined by the descriptive linguistics, and by the projection of each verbal worth into the sector of fuzzy sets. Linguistic variable values square measure verbal expressions, i.e. the linguistic variable represents the affiliation between the verbal expressions and fuzzy sets.

Linguistic variables are simply used to produce easy statements, which can be then coupled with the help of logical AND, OR operations into the complicated statements. The subsequent compound fuzzy statements created from easy fuzzy statements represent fuzzy rules.

The most common thing is to produce fuzzy rules are IF – THEN conditions. Fuzzy rule consists of 2 parts: the antecedent is the conditional part of the rule and also the sequent is that the result part of the rule.

There are 2 basic styles of fuzzy systems: Takagi-Sugeno-Kang a Mamdani. The difference between these styles of fuzzy systems lies in the resultant section. Within the system of the sort Mamdani, the antecedent and consequent is represented by fuzzy sets. Therefore, to calculate at the end in numerical kind form from the fuzzy kind, a method of defuzzification is required.

Sugeno sort models have the resultant half (also the calculation of the result) within the style of the analytical function, which is that the commonest linear or constant. Whereas, in the case of the Sugeno sort model isn't needed the defuzzification method, the usage of analytical

functions provides directly a pointy value, thereby creating the calculative method the higher speed [7].

## III. ANFIS

ANFIS is a multilayer feed forward network which employs neural network and fuzzy logic learning algorithms to design a plan from input to output. ANFIS has shown great capabilities in control process [8]. A typical design of associate ANFIS is shown in fig.1, during which a circle indicates a set node, whereas a square indicates an adaptive node. For simplicity, it had been assumed that the required logic system has two inputs  $x, y$  and one output  $z$ . Since the planned neuro-fuzzy model of the ANFIS is same as the primary order Sugeno fuzzy model, laws are as follows.

**Rule 1:** if ( $x$  is  $A_1$ ) and ( $y$  is  $B_1$ ), then ( $Z_1=p_1x+q_1y+r_1$ )

**Rule 2:** if ( $x$  is  $A_2$ ) and ( $y$  is  $B_2$ ), then ( $Z_2=p_2x+q_2y+r_2$ )

Where  $A_i$  and  $B_i$  are the fuzzy sets in the antecedent, and  $p_i, q_i$  and  $r_i$  are the design parameters that are determined during the training process. As in fig. 1, the ANFIS consist of five layers [8].

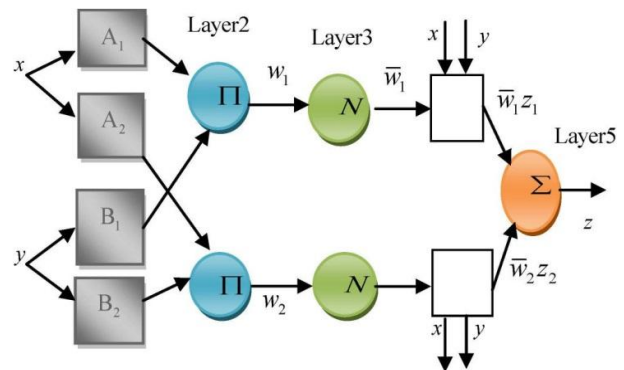

Fig. 1 Structure of ANFIS [9].

**Layer 1:** Every node  $i$  in the first layer employ a node function given by:

$$O_i^1 = \mu_{A_i}(x) \quad i=1,2 \quad (1)$$

$$O_i^1 = \mu_{B_{i-2}}(y) \quad i=3,4 \quad (2)$$

Where  $\mu_{A_i}$  and  $\mu_{B_i}$  can adopt any fuzzy membership function (MF)

**Layer 2:** Every node in this layer calculates the firing strength of a rule via multiplication:

$$O_i^2 = w_i = \mu_{A_i}(x) \cdot \mu_{B_i}(y) \quad (3)$$

**Layer 3:** The  $i$ -th node in this layer calculates the ratio of the  $i$ -th rule's firing strength to the sum of all rules firing strengths:

$$O_i^3 = \bar{w}_i = \frac{w_i}{w_1 + w_2} \quad (4)$$

Where,  $\bar{w}_i$  is referred to as the normalized firing strengths.

**Layer 4:** In this layer, every node  $i$  has the following function:

$$O_i^4 = \bar{w}_i z_i, \bar{w}_i(p_i x + q_i y + r_i) \quad (5)$$

Where,  $\bar{w}_i$  is the output of layer 3, and  $(p_i, q_i, r_i)$  is the parameter set:

The parameters in this layer are referred to as the consequent parameters.

**Layer 5:** The single node in this layer computes the overall output as the summation of all incoming signals, which is expressed as:

$$O_i^5 = \sum_{i=1}^2 \bar{w}_i z_i = \frac{w_1 z_1 + w_2 z_2}{w_1 + w_2} \quad (6)$$

The output  $z$  in fig.2 can be written as:

$$z = (\bar{w}_1 x) p_1 + (\bar{w}_1 y) q_1 + (\bar{w}_1) r_1 + (\bar{w}_2 x) p_2 + (\bar{w}_2 y) q_2 + (\bar{w}_2) r_2 \quad (7)$$

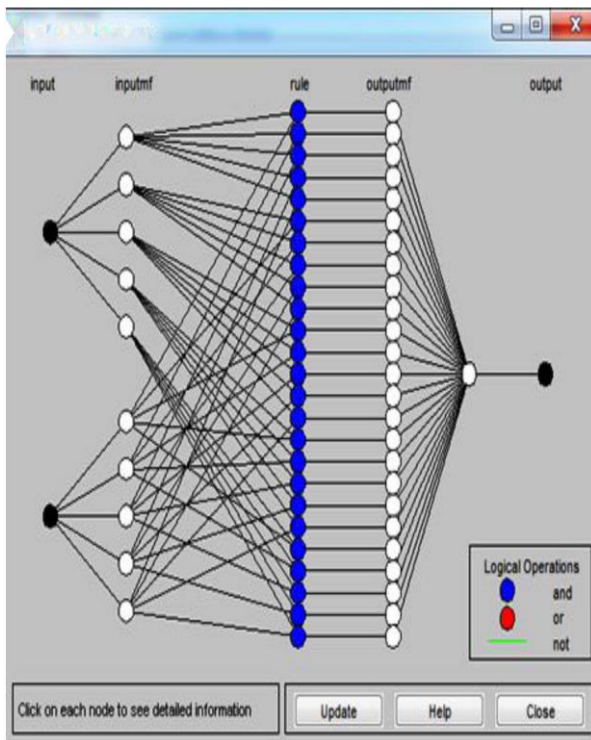

Fig. 2 The ANFIS model structure.

#### IV. SIMULATION AND MODELING

The modelling have an excellent importance as a result of it's potential to find out behaviour of existing systems or projected systems and conjointly approximate reaction of atmosphere and simulate processes, which may be found in nature by modelling. It is also possible to predict several things and its method behaviour.

These models becomes necessary over time, in terms of safety there's no risk to wreck the important system by using model, therefore avoiding the possible loss of life or damage to nature. Financial resources can be saved, because it is not necessary to use real system, which implies the necessity to interrupt its activities in some cases, which is not always possible.

The usage of the model can even avoid monetary losses caused by damaging of real system. Advantage of models is low worth compared to cost of realization and price of your time needed to its realization. Because the models are

non-destructive, we can repeat experiments infinitely, and it's additionally potential by changing the time duration.

#### A. MSC ADAMS

MSC Adams is computer code engineering tool for making and analysing of the kinematic-dynamic models of pure mathematics and technology structures and systems. It permits modelling of motions, force effects, contacts, gears, spring struts, etc. This software works solely with rigid bodies, it doesn't support modelling of plastic-elastic properties of bodies and it's designated to motions and force effects studies [6].

Software additionally provides simple pure mathematics creation or permits user to import pure mathematics from different CAD software's. Except these options Adams might be joined with different software's like MATLAB or FORTRAN together with these systems provides options that Adams itself doesn't contain. Connected programs will along produce the co-simulation wherever a model from Adams determines kinematic-dynamic model and the other, e.g. MATLAB determines the management and regulation of Adams model.

#### B. Co-simulation by MSC Adams and MATLAB-Simulink with Fuzzy Model

Cooperation of ADAMS and MATLAB software package environments relies on kinematic-dynamic model created in Adams. This model represents a controlled system [6].

Adams surroundings offer large quantity of physical characteristics. There are many step procedure a way to assign these characteristics to input and output variables. First step is to measure or scan chosen physical properties. Later it has to be created state variables in Adams surroundings; next step is to assign chosen physical properties to created state variables, and at last to choose which variables are going to be used as input and output ones. This will guarantee interconnection of these 2 software system environments. Later on the system is exported to file supported by MATLAB. Exported system are going to be loaded into MATLAB as information at first, and later converted to a block illustration in Simulink. The Adams model now can be employed in control loop in Simulink.

Co-simulation is initialized by running simulation in MATLAB-Simulink setting. Undesirable, but obvious impact of co-simulation is increasing quality of calculations and therefore considerably increasing simulation time. Data transfer in Adams is accomplished by variables assigned to inputs and outputs, which are in MATLAB reflected to a Simulink block (subsystem) with acceptable range of input and output connections.

In the block diagram we can see that there is a control loop having fuzzy controller in feedback loop structure having 4 input and 2 output variables. The input to the controller is control deviation and the derivative of control deviation of two angles which is manipulating with arm. The output of the controller is torque which is reacting in the rotational joints [10][11].

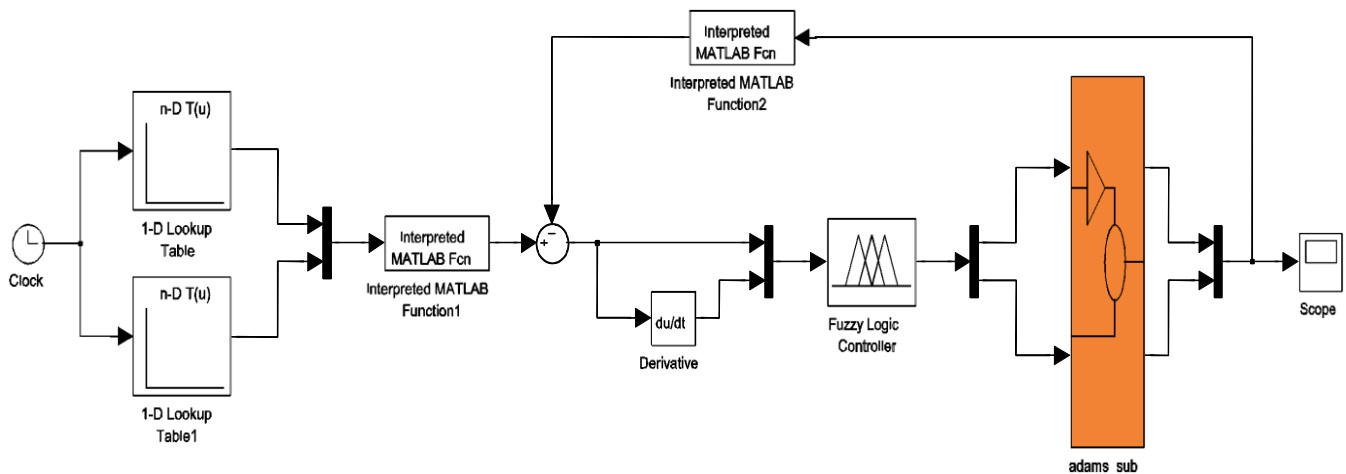

Fig. 3 Block scheme of control loop for fuzzy[6]

Mamdani fuzzy system is used as a fuzzy controller. For first input i.e. control deviation 5 membership functions is used in the range of  $-180^0$  to  $180^0$  of gauss type. For second input i.e. derivative of control deviation 3 membership function is used in the range of  $-35^0/s$  to  $35^0/s$  of gauss type. For the output i.e. torque 7 membership function is used of triangular type. The range of first angle is  $-50Nm$  to  $50Nm$  and for the second angle  $-25Nm$  to  $25Nm$ . To relate all these input output membership function total 30 fuzzy rules are required. This could be also done by two separate controllers, but the decision was to do it as one MIMO controller.

The reference trajectory is set by two lookup tables. The upper one represents the trajectory points along x-axis w.r.t time, the lower one along y-axis w.r.t time respectively. Succeeding blocks represent MATLAB-function for computation of coordinates to reference angles of each robotic arms. Behind the analysis of the control deviation and its derivation for each angle are feeding as input signals to the fuzzy controller. The output of the controller is feed to the MSC Adams as input and the output of controller is torque for the robotic arms. The orange subsystem represents exported mechanical model from Adams surroundings. Because the output of the Adams model is located the simulation coordinates of the marker on the end of robotic arm.

The recalculation from coordinates to angles is given by equations:[6]

$$\Phi_1 = \text{atan}(y/x) - \text{acos}((\sqrt{x^2+y^2})/2r) \quad (8)$$

$$\Phi_2 = -2(90 - \text{acos}((\sqrt{x^2+y^2})/2r)) \quad (9)$$

Where,

x represents coordinate x

y represents coordinate y

$\Phi_1$  represents angle of the first arm

$\Phi_2$  represents angle of the second arm

r represents length of one arm

As we discussed earlier there is problem in this model i.e. trajectory tracking problem. To overcome this ANFIS is introduced.

### C. Co-simulation by CATIA and MATLAB-Simulink with ANFIS Model

CATIA is an integrated software system of CAD, CAE and CAM that is widely used in automotive industry [12]. With the parallel working environment provided by CATIA, the product design, analysis and manufacturing can be finished in the same interface. The conversion between data models can be avoided. CATIA provides special modules of DSE, FS, GSD and FSR for the reverse design [13]. CATIA not only can support kinds of point cloud files, but also can support three curved surface description methods of Bezier, MURBS and B-spline. It has large function of surface modelling. The finite element analysis module in CATIA is simple and reliable. The reverse engineering has been widely studied at home and abroad. According to the features of complex shape and big structure strength for tractor panel, the reverse design of the tractor panel based on the CATIA is studied in this paper. On this basis, the finite element analysis of the tractor panel is taken on.

Shape improvement is a component of the sphere of best management theory. The standard downside is to seek out the form that is perfect in this it minimizes a particular value useful whereas satisfying given constraints. In several cases, the useful being resolved depends on the answer of a given partial equation outlined on the variable domain form improvement strategies add a set of allowable shapes that have mounted topological properties, like having mounted range of holes in them.

Below there are three figures showing Fig. 4 shows the original shape of the robotic arm which is unoptimized. Fig. 5 shows that the proposed or estimated shape of the robotic arm. And final Fig. 6 shows the optimized arm which is optimized by engineering tool or software. Shape optimization is done by CATIA.



Fig. 4 Unoptimized arm shape (original)



Fig. 5 Proposed optimized arm shape



Fig. 6: Final optimized shape

Below fig shows arrangement of ANFIS model with CATIA.

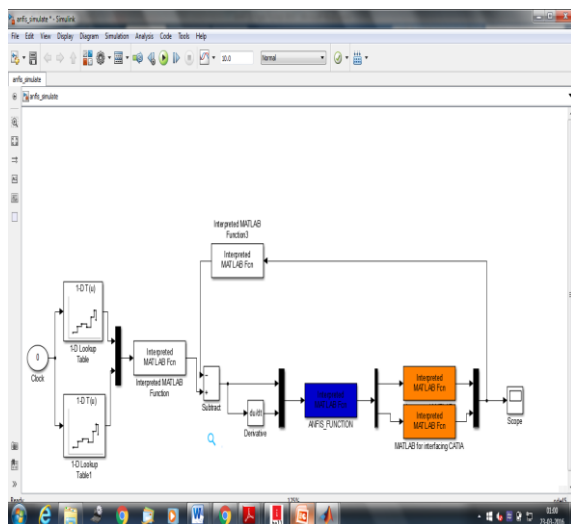

Fig. 7 ANFIS model with CATIA

The problem of trajectory tracking is overcome by this proposed model. ANFIS is trained by training. In simple sense we can say that if input and output is known then the performance system is enhanced. Similar is thing happening in ANFIS model according to the data provided by the training data the adaptive nature of ANFIS draw the inference for that data. If the data is too precise and too close then the result is exceptionally good one. If we provide a close training data angle then the trajectory of arm is very close and stability will be achieved.

Fig. 7 shows the simple arrangement similar as fuzzy model the difference is that fuzzy function is replaced by the ANFIS model and MSC Adams is replaced by the CATIA and the rest of things are same. ANFIS has 4 input with combination of two i.e. control deviation and derivative of control deviation, the output of the ANFIS is torque which then fed to CATIA. From the CATIA another MATLAB interpreted function is getting the input where again the recalculation of angle will take place and this recalculated angle is compare with past one gives the deviation as a result and this loop is continue till to the destination.

## V. RESULT AND CONCLUSION

This paper centred on the applications and usage of soft-computing methods. Soft-computing strategies are

successfully deployed in wide field of mechatronic and robotic system control and because it is given within the case study, it's possible to obtain wonderful results in terms of performance and stability.

Designed of fuzzy controller in fuzzy model is suitable for single model means the rules which are made for another model. For completely different models got to be designed new fuzzy controller with fuzzy rules acceptable to the model. Adequate experience and information of symbolic logic, rules and systems are needed.

The weakest purpose of planned fuzzy controller model is that the trajectory tracking within the little surround of the initial point [0,0] wherever a small change of coordinates, leading to great change of angles, might cause the unstable control of the closed-loop system. Possible answer of this downside is to give enough time to the controller for trailing the reference coordinates.

In ANFIS system training data is very important the whole model is depending upon the training data trajectory is smooth and stable when the training data has high level of closeness among them because training data decides the trajectory of whole system so training data angle is very important to ensure the stability of the system.

In this present work an arm manipulator using two styles of controls i.e. fuzzy model and ANFIS model. ANFIS present most control structure of our control model and provides more and more efficiency for the robot with additional position stability and smart impulsive performances with no overshoot therefore industries would take under consideration the efficiency for the developing control model for the futures robot design considerations.

## REFERENCES

- [1] Zomaya, A.Y. , Modelling and Simulation of Robot Manipulators. A parallel processing approach, world scientific publishing co. pvt. Ltd., Singapore 1992.
- [2] N. A. M. Johari, h. Haron, A. S. M. Jaya, "Robotic Modelling and Simulation of Palletizer Robot using Workspace5", IEEE conf. on computer, graphics, imaging and visualization, Bangkok, Thailand, Aug 2007.
- [3] P. Sumanthi, "Precise tracking control of robot manipulator using fuzzy logic", DARH2005 conference, session 4.1.
- [4] M. Kevin Passino and S. Yurkovich, fuzzy logic, Addison Wessely Longman 1998.
- [5] Jang J. S. R, "Adaptive network based fuzzy inference system", IEEE transaction on system man and cybernetics 1993 p. 665-685.
- [6] Zadeh, L. A.: fuzzy sets , information and control 1965 8(3): 338-353
- [7] J. Ciganek, F. Noge, G Galik and R. Gogola, "Fuzzy tracking controller for shape optimized robotic system", IEEE 23<sup>rd</sup> Int. conf. on robotics in Alpa-Adria-Danube region, Somelnice castle, Slovakia, Sep 2014.
- [8] B. Allaoua, A. Laoufi, B. Gasbaoui and A. Aaderrahani, "Neuro-fuzzy dc motor speed control using particle swarm optimization", Leonardo electronic journal of practices and technologies issue 15, July-Dec 2009.
- [9] F. Z. Baghli, Y. Lakhali, El Bakkali, O. Hamdoun, "design and simulation of adaptive neuro fuzzy inference system (ANFIS) controller for a robot maipulators", IEEE complex system (WCCS), second world conference, Agadir, 2014.
- [10] J. Ciganek and F. Noge, "Fuzzy logic control of mechatronic system", IEEE Int. conf. on process control, Strbske Pleso, Slovak Republic, 2013.
- [11] J. ciganek and F. Noge, "Fuzzy logic control of robotic arm", the 22<sup>nd</sup> Int. workshop on robotics in Alpe-Adria-Daunde region, Portoroz, Slovenia, 2013.
- [12] P. Xong, Q. Ding, "Application of CATIA V5 in the structure designing of auto parts", CAD/CAE and manufacturing information no. 11, 204 pp 47-48.
- [13] X. Wang, H. X. Liu, "Practical course of CATIA reverse engineering", publishing house of chemical industry, 2006, pp 36-37.