

# Survey on Energy Efficiency using LEACH for Retransmission Problem

Vishal kaushal<sup>1</sup>, Shivi Sharma<sup>2</sup>

M.E. Student, Department of Computer Engineering, LR Institute of Engineering and Technology, Solan, India<sup>1</sup>

Assistant Professor, Department of Computer Engineering LR Institute of Engineering and Technology, Solan, India<sup>2</sup>

**Abstract:** There are number of routing protocols that is energy saver or energy reducer for improving the performance of the network. LEACH is one of the important protocols that we say, energy saver protocol. This protocol may problem in the case link failure and distortion of the network. The current selecting approach will be working on the areas of energy depletion that may occur like link/path distortions. The proposed technique finds out the MAC and Retransmission delay that solves the energy problem in sensor network.

**Keywords:** WSN, LEACH, RREP, RREQ, MDC, MAC.

## I. INTRODUCTION

A wireless sensor network (WSN) consists of spatially distributed autonomous sensors nodes to monitor physical or environmental conditions, such as temperature, sound, pressure, etc. and to pass the results through the network to a requested location. WSN is built of nodes where each node is connected to one or more sensors. Sensor nodes are the network components that will be sensing and delivering the data and depending on the routing algorithms used Sensor Nodes have some properties that have capability to improve the routing functionality.

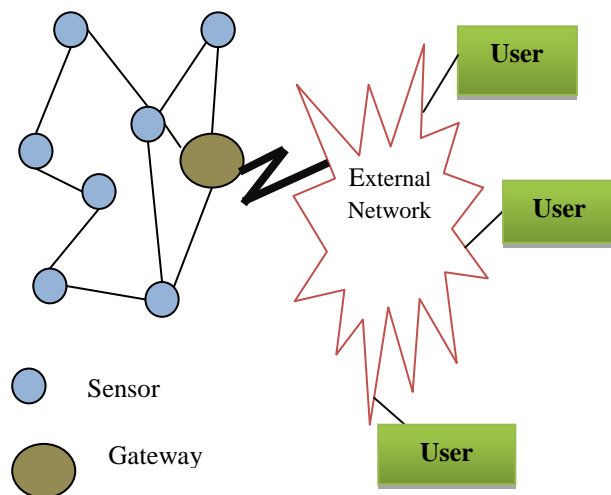

Fig. 1 WSN Architecture

The architecture has been shown in figure 1, and here, it is described in following points:

1. A sensor node might vary in size. Depending upon the size and complexity of sensor node, its cost of may vary.
2. The topology of the WSNs can vary from a simple star network to an advanced multi-hop wireless mesh network.
3. The propagation technique between the hops of the network can be routing or flooding.
4. The Gateways also needed to act as a bridge between the WSN and the other network.

## II. AODV PROTOCOL

The AODV protocol keeps a route table to store the next-hop routing information for destination nodes. Each routing table can be used for a period of time. If a route is not requested within that period, it expires and a new route needs to be found when needed. Each time a route is used, its lifetime is updated. When a source node has a packet to be sent to a given destination, it looks for a route in its route table. In case there is one, it uses it to transmit the packet.

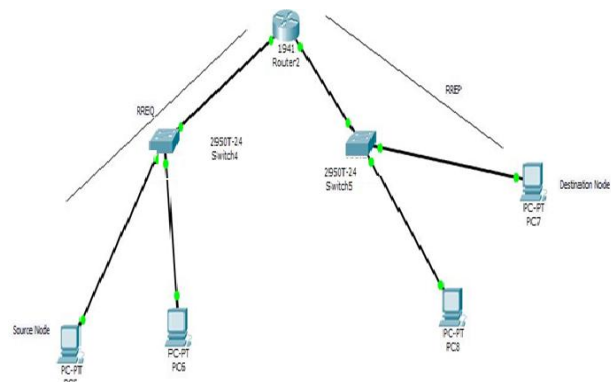

Fig 2: RREP and RREQ message sent on Multi-routing Devices

Upon receiving a RREQ message, a node performs the following actions: checks for duplicate messages and discards the duplicate ones, creates a reverse route to the source node (the node from which it received the RREQ is the next hop to the source node), and checks whether it has an unexpired and more recent route to the destination (compared to the one at the source node).

## III. CLUSTERING/MULTICASTING

Multicast is the delivery of messages to a group of destinations in such a way that it creates copies only when the links to the destinations split. Finally, broadcast is the delivery of a message to all nodes in the network. A multicast routing protocol is employed when a mobile

node wants to send the same message or stream of data to a group of nodes that share a common interest.

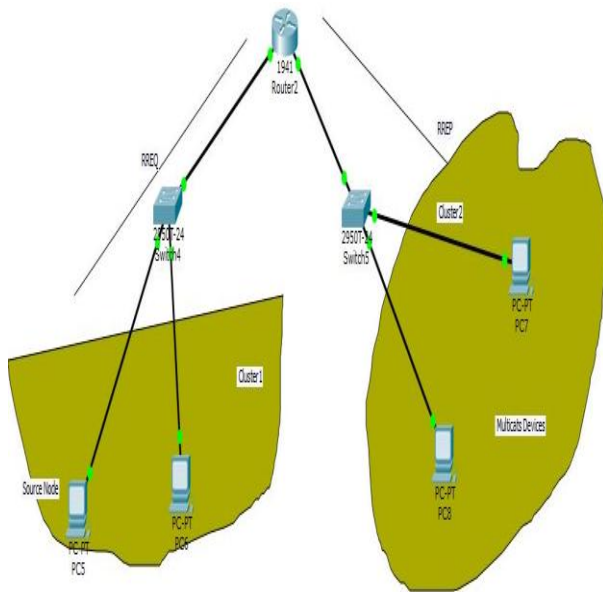

Fig. 3 Example of Clustering

Clustered ad hoc network is dynamically organized into partitions, called clusters, whose objective is the maintenance of a relatively stable topology. Clustering in ad hoc networks can support hierarchical routing, make the route search process more efficient for reactive protocols, support hybrid-routing in which different routing strategies operate in different domains or levels of a hierarchy, and provide more control over access to transmission.

Selection of cluster heads and partitioning of the nodes into clusters are essential aspects of mobile ad hoc networking. A clustering algorithm is basically a multileader election problem, and a cluster is similar to a group in distributed systems. Nodes within the cluster are considered members of the cluster head of that particular cluster. Sometimes, to be a member of a cluster head, a node has to lie within the transmission range of that cluster head. Nodes within the transmission range of more than one cluster head are usually called gateway nodes (as shown in figure 1).

The deployment of ad hoc networks simply eliminates the cost of laying cables and maintenance of an infrastructure. In order to have a partially functioning network immediately, an incremental deployment with minimal configuration is possible.

#### IV. LITERATURE SURVEY

Muhammad Arshad, Mohamed Y. Aalsalem, Farhan A. Siddiqui discussed wireless Sensor Networks operated on the network Layer of the OSI Model and responsibility of delivering messages and creates best routes for transmitting data throughout the network. The authors has introduced the clustering concept that solves the issues of hot spot and aim of this research is evaluating and

validating the Mobile Data Collector-based routing protocol maximum residual energy LEACH) with a Novel Application Specific Network Protocol for Wireless Sensor Networks routing protocol. This proposed protocol for multi-hop cluster-based routing for environmental applications in WSNs. It makes use of a mobility model with a pre-defined trajectory. The MDC maximum residual energy LEACH routing protocol possessing a maximum level of residual energy makes use of a basic First Order Radio Model. After the cluster formation, the cluster head sets up the TDMA schedule for every node to send data to the cluster head [1].

Sai Prakash S K L V, Kondapalli S Rami Reddy focuses on two sink node selection algorithms corner node method and the centre node method and their impact on the tree formation. Once the sink node is selected by one of the above two approaches, level based connectivity tree formation is used for constructing the tree in the network. In this level based connectivity, levels are assigned to the nodes based on the distance from the sink node as well as the level of its branch node [4].

Aboobeker Sidhik Koyamparambil Mammu, Ashwani Sharma, Unai Hernandez-Jayo, Nekane Sainz detailed overview of Clustering through formation of hierarchical WSNs that helps in efficient use of limited energy of sensor nodes and hence improves network lifetime. During information collection phase CH gathers information from all of its cluster members and after its aggregation forwards to the next adjacent CH and last to the sink node. The conventional problem could be avoided by efficient rotation of CH nodes and provided a major breakthrough in cluster based data collection in WSNs. Furthermore, regular re-election of CHs within clusters depending on their remaining energy is a possible way to reduce the total energy consumption of every cluster. In addition, clustering scheme must be developed for various application scenarios to have capabilities like scalability, transmission coverage, prolonged lifetime, robustness, and simplicity [3].

#### V. MOTIVATION OF WORK

In early stage, sensor nodes elected as Cluster Head that absorb more energy as compared to other cluster members [3], due to their long range or multi hop transmissions to the sink node, and may lead to an irregular energy consumption of sensor nodes in the (WSN) Wireless Sensor

Networks. The Maximum Residual energy named MDC with LEACH protocol has introduced by the earlier work [1] and improves the residual energy but still the data has overlapped with each other and our aim to route the data efficiently and reduces the overhead.

This research work put emphasis on addressing the depletion of energy during communication for not only the process of transmitting but also receiving. Furthermore, the amount of energy dissipation from the sensor nodes directly impacts on network lifetime.

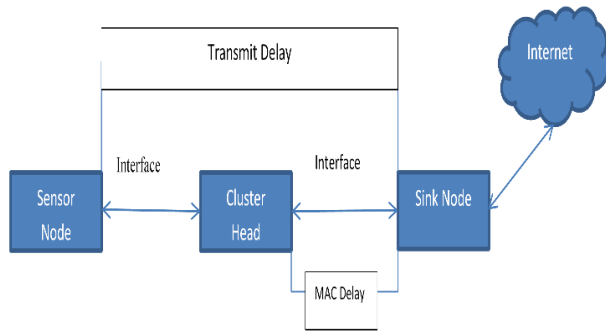

Fig 4 Proposed Scenario

In this paper, the following figure 4 has been shown for carried out the whole process in simulated environment. This proposed scenario find out the MAC delay and to connect different sensors on the network. LEACH protocol has deployed on the network scenario for finding the energy depletion or consumption so that we shall be improving the overall network performance.

**VI. PROPOSED TECHNIQUE**

The fig 5 showed the proposed approach that is the enhancement over LEACH protocol. This technique reduces the unnecessary time outs and MAC delays on the network. If the path / link have broken in the network, path connectivity not establishes then the proposed technique follow new route for making the connection between sources to destination machine.

**VII. CONCLUSION**

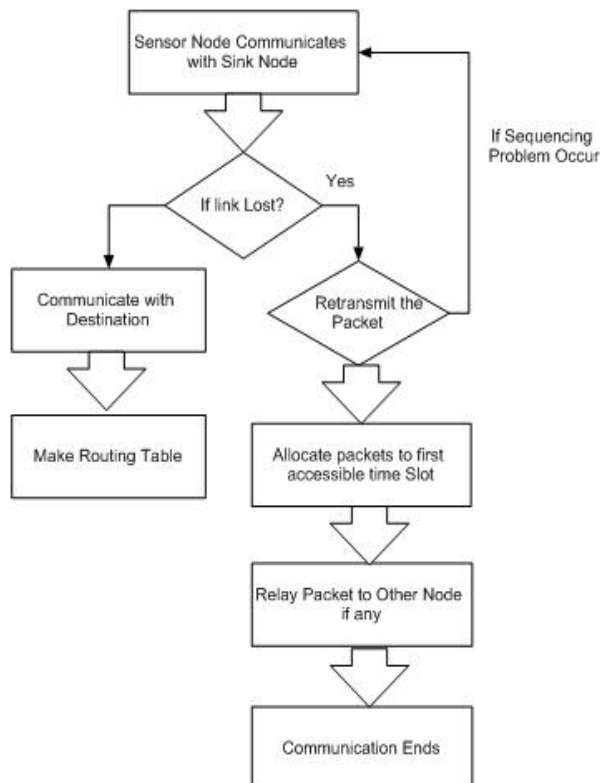

Fig 5 Proposed Flowchart

This paper highlights the multicasting and clustering approaches, that is the current topic of wireless sensor networks. This approach utilizes better when it applies on mountain areas but Ad Hoc and 3 G fails to send the data on these areas. It is also assumed that energy constraint problem might be there on these areas. The LEACH protocol has been used in this clustering approach for successful transmission of data. We introduce the proposed technique that solves the delay and retransmission problems occurred during path fading/link lost.

**REFERENCES**

- [1] Muhammad Arshad, Mohamed Y. Aalsalem, Farhan A. Siddqui, "Energy Efficient Cluster Based Routing Scheme for Mobile Wireless Sensor Networks", IEEE, 2014.
- [2] Debashis De, Aditi Sen, Madhuparna Das Gupta, "Cluster Based Energy Efficient Lifetime Improvement Mechanism for WSN with Multiple Mobile Sink and Single Static Sink", IEEE, 2012, pp.197-199.
- [3] AboobekerSidhikKoyamparambilMammu, Ashwani Sharma, Unai Hernandez-Jayo, NekaneSainz, "A Novel Cluster-based Energy Efficient Routing in Wireless Sensor Networks", IEEE, pp.41-47, 2013.
- [4] Sai Prakash S K L V, Kondapalli S Rami Reddy, "Performance Evaluation of Sink Node Selection for Time Synchronization in WSN", IEEE, 2014.
- [5] ParminderSingh, Damandeep Kaur, "An Approach to Improve the Performance of WSN during Wormhole Attack using Promiscuous Mode", International Journal of Computer Applications, pp.26-29, 2013.
- [6] AnatoliyPlatonov, Ievgen Zaitsev, "Performance of PHY Layer Links of WSN: Criteria and Ways of Improvement", IEEE, 2013.
- [7] Gabriel Mujica, Rafael Zamacola, Jorge Portilla, Teresa Riesgo, "Performance Evaluation of an AODV-Based Routing Protocol Implementation by Using a Novel In-Field WSN Diagnosis Tool", IEEE, 2014.
- [8] Hyun Cheol Jeon i, Chan Gook Park, "Analysis of convergent beam to improve sensor node positioning performance in Optics-based WSN", ICCAS, pp.866-869, 2014.
- [9] Amit Patwardhan, "Energy based path planning for wireless sensor networks", International Journal on Emerging Technologies", pp.16-18, 2010.
- [10] Surendrabillouhan, Roopam Gupta, "Optimization of Power Consumption in Wireless Sensor Networks", International Journal of Scientific & Engineering Research, pp.1-5, 2011.