

Gesture Based Vocalizer for Deaf and Dumb

Supriya Shevate¹, Nikita Chorage², Siddhee Walunj³, Moresh M. Mukhedkar⁴

Electronic and Telecommunication, Dr.D.Y.Patil College Of Engineering Ambi, Talegaon Dabhade, Pune, India^{1,2,3,4}

Abstract: Gesture Vocalizer is a project for social purpose. From the survey we found that it is really very difficult for deaf people to communicate with other people. Normally deaf people speak with hand gestures and it is difficult for other people to understand their sign language. We are going to implement gesture based vocalizer which will detect all the gestures of deaf people and convert it into voice and also can display it on LCD screen .For that we are making use of ARM 7 controller to interface all of the sensors and speech synthesizer .Basically data glove contains two types of sensors flex sensor and accelerometer as a tilt sensor. A wireless data gloves is used which is normal cloth driving gloves fitted with flex sensors along the length of each finger and the thumb. Dumb people can use the gloves to perform hand gesture and it will be converted into speech so that other people can understand their expression.This system is useful for dumb people to communicate with other people .

Keywords: Gesture Detection, Data Glove, Bend Detection, Tilt Detection, Speech Synthesizer, LCD display

I. INTRODUCTION

In our daily life we used speech & gestures of hand for communication between human beings. Research in this project aims to integrate the gesture Human Computer Interaction (HCI).

For communication between human beings gestures and speech are completely coordinated to each other. This paper analyses the data from data glove for recognition of signs and the gestures.

A system is designed for recognizing these signs and their conversion into voice. The result of this design expects the accurate and noiseless conversion of gestures into voice. A gesture in a sign language is movement of fingers and tilting of hand in particular directions with specific angles. Signs language consists of different signs for different words.

It also contains of different sign for different letters to create words that don't have any sign in that sign language. In this device we used Flex sensors which plays a major role in our project.

Flex sensors are used at each finger of hand. When we bend our fingers it changes the resistance which in turn converted into voltage. It is the device which contains data glove that can translate Sign language into speech to make the communication between the deaf people with normal people easily.

We are using ARM7 controller for interfacing the communication between deaf and normal people. We are also displaying the conversion of gestures in the form of text on LCD display for the people who are unable to hear the voice.

So that they can easily communicate with the deaf people.

II. BLOCK DIAGRAM

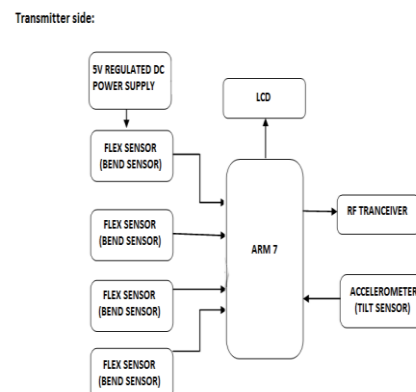

Fig. No.1. Block Diagram of Transmitter

III. BLOCK DIAGRAM DESCRIPTION

3.1 Flex Sensor:

Flex sensors plays the major role in Gesture Vocalizer. Flex sensors in gesture vocalizer is used as bend sensors. We connect the flex sensors at each finger of hand. Flex sensors are used to detect the bending of fingers. We are using the flat resistance of 10K. the voltage varying between 0-5 volt. As the bending of finger is minimum the voltage at output is maximum that is 5v and vise versa. The resistance value is converted into voltage. That should be used in situations when you want output at allow degree of bending.

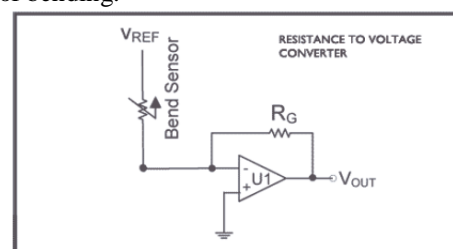
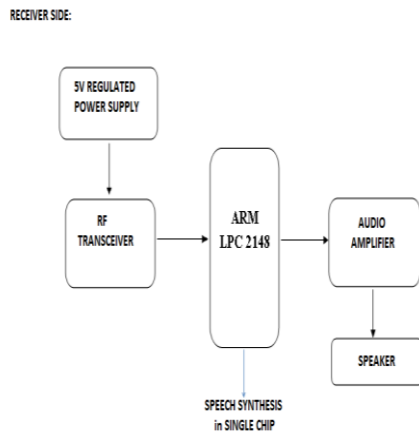
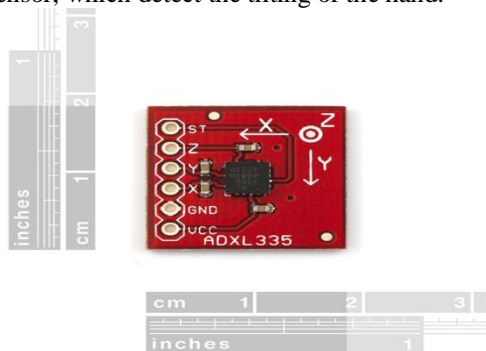

Fig. No.3.1. Flex sensor circuit



3.2 Accelerometer:

Accelerometer in the Gesture Vocalizer system is used as a tilt sensor, which detect the tilting of the hand.



3.3 Tilt Detection:

Accelerometer is used to detect the bending of the hand and sending the data, to the bend detection module. The output of accelerometer is obtained by amplification. The output of the accelerometers is an analog output. To convert it into digital form we have to connect it to the ADC of the microcontroller. This Gesture Vocalizer system is a dual axis system, which can detect the tilt of the hand in two axes.

3.4 Analog To Digital Converter:

ADC can be used to convert the outputs of two accelerometers in to digital form. So at first, the ADC converts the analog signal to the digital form and then the second ADC converts the analog signal of second accelerometer into digital form. The output of the accelerometers is converted into the digital form. This output is detected by the microcontroller. It is then used for converting it into voice.

3.5 Microcontroller:

The microcontroller checks the data from the ADC's. The microcontroller checks, whether the data received from the ADC's have some meaning. Meaning means that each and every gesture that ach tilt as well as bend have some meaning in the sign language. We are storing that meaning in the buffer of our microcontroller. When deaf people making any sign which have some meaning microcontroller will accept it and store in the buffer. It then send it to the speech synthesizer for the following

purpose. We are storing different meanings of gesture in the microcontroller. We can also store different letters in controller so that the controller can create its own library which has not been stored in the controller. The data is sent by the tilt detection module, and the "bend detection" module. The "bend detection module" sends eight bit data to the speech synthesises module that knows the meaning of each data.

3.6 Bend Detection:

The bend detection module is the most important and the core part of the project. At first the microcontroller takes input of the four-bend sensor. Output of the four bend sensors is given at the separate pin. Microcontroller works on flex sensors sequentially.

3.7 Gesture Detection:

Gesture detection is the most important part of this module. The bending of the finger is detected in this module. The bending of the finger has many numbers of bends, and the system is very sensitive to the bending of the finger. Now the next step is to combine the movement of each finger. It can be named for particular gesture of the hand. Now the system reads the movements of four fingers. Instead of reading the individual finger it reads all the fingers simultaneously. After reading the bending of the fingers, the system checks whether the bend has some meaning or not. It also checks the bend is useless or undefined bend. If the bending of the fingers gives some meaningful gesture, then system moves towards the next step. In the next step the system checks the data, which was sent by tilt detection module in microcontroller. The data sent by this module shows whether the tilt of the hand has some meaningful gesture or it is undefined. If the tilt of the hand is also meaningful then it means the gesture as a whole is a meaningful gesture. Till now it is detected by the system whether the gesture given by hand is some meaningful gesture, or a useless one.

3.8 RF Transceiver:

The CC2500 is 2.4 GHz transceiver. It is designed for very low-power wireless applications It is low cost transceiver. We are using RF Transceiver for wireless communication via SPI interface. The circuit works for the ISM and SRD frequency band at 2400-2483.5 MHz. The main operating parameters and the 64-byte transmit/receive FIFOs controlled via an SPI interface.

3.9 Speech Synthesis:

This module of the system is consisted of a ARM LPC2138/48, speech synthesizer, amplifier circuitry and a speaker. The function of this module is to produce voice against the respective gesture. The LPC2138/48 receives the eight bit data from the "Bend Detection" module. It compares the eight bit data with the values that has already been defined in the microcontroller. On the basis of this comparison, the microcontroller comes to know that which gesture does the hand make. Now the microcontroller knows that which data is send by the bend detection module, and what is the meaning of the data sent by

gesture detection module. Which means that the microcontroller can understand, whether the hand is making some defined gesture and what should the system speak. The last step of the system is to give voice to the each defined gesture. We must know the address of each word or sentence or letter which is to be spoken by this module. Now these addresses are already stored in the microcontroller. Till now, the microcontroller knows what is the gesture made by the hand, and what should be spoken against it

3.10 LCD Display:

By using the gesture vocalizer the dumb people can communicate with the normal people and with the blind people as well, but the question arises that how can the dumb people communicate with the deaf people. The solution to this problem is to translate the gestures, which are made by the hand, into some text form. The text is display on LCD.

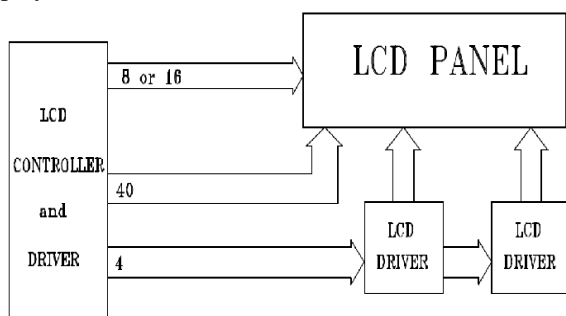

Fig. Block Diagram of LCD Module

IV. CONCLUSION

This system is useful for dumb, deaf and blind people to communicate with one another and with common people. The dumb people use their sign language which is difficult for common people and blind people to understand. This system converts the sign language into speech which is easy for blind and normal people to understand their language. The sign language is translated into some visual form, to understand for the deaf people also. This text is display on LCD. Sign language is a useful for communication between the deaf community and the normal people. This project is basically designed to minimise the communication gap between the dumb people and the normal one. With this project the dumb people can use the data gloves. Which is used to perform sign language and it will be converted into voice so that normal people can easily understand and also display it on LCD so that people who cannot hear can read it on the screen.

V.FUTURE SCOPE

- Perfection in monitoring and sensing of the dynamic movements involved in "Gesture Based Vocalizer".
- Designing of a jacket, which would be capable of recognizing the gestures and movements of animals.
- Virtual reality application e.g., replacing the conventional input devices like joy sticks in video games with the data glove.

- The Robot control system to regulate machine activity at remote sensitive sites.

REFERENCES

- [1]. A review on hand gesture system] Mr. Prashant Chaudhari , E&TC Department ,Government College of Engineering, Maharashtra-425001(INDIA) Prof. G. R. Phulay Asst. Prof. in E &TC Government College of Engineering, Jalgaon, Maharashtra 425001(INDIA)Mr. Ravindra Patil E&TC Department Government College of Engineering, Jalgaon,Maharashtra-425001(INDIA)(Jan 2013).
- [2]. The amazing digital glove that give voice to voiceless Praveenkumar S Havalagi, Shruthi Urf NiveditaM.Tech (VLSI), Department of ECE, SIET, Bijapur, India,B.E (ECE), Department of ECE, SIET, Bijapur, India(MAR 2013).
- [3]. Innovative Approach for Gesture to Voice Conversion Priyanka R. Potdar JSPM's Bhivrabai Sawant Institute of Technology & Research (W) University of Pune, Pune, Maharashtra, India Dr. D. M. Yadav,Principal, JSPM's Bhivrabai Sawant Institute of Technology & Research (W) University of Pune, Pune, Maharashtra, India(June 2014).