



AUTO RAILWAY PLATFORM CONTROL USING SENSORS

Nandish M M¹, Nitturu Naga Sheshu², Prashanth P³

Department of ECE, SJC Institute of Technology, Chickballapur, Karnataka, India¹⁻³

Abstract: Railways place a premium on passenger safety. The goal of this study is to build a control at platform while the passengers crossing the platform with automation operation in response to the arrival and departure of trains. As a train approaches the crossing, the gate closes automatically. Two infrared sensors monitor the tracks and alert the operator when a train approaches or departs. Motors, controlled by an Arduino Uno, will operate the gate's opening and shutting. The closure of the gate is signalled to those waiting to pass using buzzers. The growing frequency of accidents at platforms in India may be mitigated with the use of this method. Arduino C code provides hardware support. There is less waste and greater safety in the suggested approach.

I. INTRODUCTION

As things stand now, railway safety is of paramount importance in the global rail industry. It's common knowledge that trains are the most economically viable means of transportation, yet mishaps are commonplace because of the need for human intervention. All throughout India, 30348 level crossings may be found on the Indian Railways. Out of a total of 303048 level crossings, 18785 need human intervention and 11563 do not. During the last five years, Indian Railways' regional divisions have eliminated 4,792 dangerous level crossings. With the availability of railway money, the Indian Ministry of Railways took a decision to remove all level crossings that could be managed mechanically.

The proposed system is useful for ensuring the safety of unmanned level crossings and avoiding accidents. When a level crossing is not staffed, accidents are more likely to occur, and dependable operation is essential, the Automated Railway Gate Control System might be used. The suggested concept recommends an automated method, which eliminates human mistake and makes it ideal for usage as a trustworthy data source. Based on the arrangement done using Arduino and Servo motor, the suggested model of automated gate control at level crossings is very good and can be used in practically all non-man handled, that is unmanned, railway crossings. The model proposes a plan for operating a railway crossing gate using a servo motor and an Arduino controller. Arduino uses a driver IC to connect to the motor, allowing it to operate the railway gate. The train's arrival is tracked by two infrared (IR) sensors, and the train's departure is tracked by another pair of infrared (IR) sensors. Infrared sensors ensure the gate has completely closed [1-10].

II. LITERATURE SURVEY

[1] P. et al. System for protecting farmland from animals and an automatic watering system were proposed. Sensing the surroundings and transmitting that information to an Arduino is what this project is all about. Infrared (IR) sensors detect animals, and a soil moisture sensor determines whether the soil is wet enough for the water pump to turn on and off by itself. But, the system does not make use of cutting-edge technology in order to notify the farmer and identify animals on the farm. T. K. Kmr et al. [12] The use of computer vision to automate the monitoring of agricultural fields is proposed. With this setup, long-range cameras are strategically positioned near the corner of a field or plot of land to make the most of their field of vision. When an animal is seen, the camera determines how far away the speaker is. The closest speaker to the animal is named. The COCO dataset and the YOLO V3 model have been pre-trained to do the object detection.

The speaker closest to the animal triggers the alarm. Nevertheless, this method fails under some conditions, such as low light or darkness (shadow). A system for protecting crops against insects, pests, locusts, small animals, and an automated watering system that monitors soil moisture, humidity, and temperature was suggested by Daminikalra et al. [13]. The crops are guarded via acoustic technology and a motion detector based on ultrasonic waves. The primary benefit of this technology is that it may be used regardless of the lighting conditions, even the dead of night (shadow). M Researchers Jaya et al. [14] presented a technique to safeguard crops from animals. This system includes an infrared (IR) sensor for animal detection, an ultrasonic (UT) sensor that can identify birds from any angle, and a GSM (Global System for Mobile) module that can transmit a warning message to the farmer. It's a basic mechanism that can't tell the difference between humans and other animals.



III. EXISTING SYSTEM

In general, in railway stations usually we used to go through bridges, but it is very difficult for the old people or handicapped people and the passengers to use the bridge and most of the accidents occur while crossing one platform to other platform and most of the passengers cross the platform by the tracks risking their lives.

IV. PROPOSED SYSTEM

In this proposed system we are planning to implement a new system to overcome the drawbacks while crossing the platforms. Deaths human while crossing the platform, by using the IR sensor and LCD, Buzzer we are design the project for railway platform control device. The platform gates will open automatically while train is arriving the station and open while train leave the platform so that passengers can easily cross the platform easily. By this we can save the valuable lives of the passengers. Our system employs a total of 2 ultrasonic sensors, which are utilised to monitor for train arrival from each direction and to monitor for train departure. The average speed of a train in India is around 67 kilometres per hour, with the greatest speed being about 97 kilometres per hour and the lowest speed being around 50 kilometres per hour. When taking into account all possible train types and train speeds, the optimal distance for infrared (IR) sensors to detect a train is between 6 km and 7 km from the crossing station, and the optimal distance for IR sensors to detect a train departure is between 2 km and 3 km from the railway crossing.

Components include infrared (IR) sensors, motors, light-emitting diodes (LEDs), a buzzer, an Arduino Uno, and a Infrared sensors record when a train enters or exits a station. The railway gates may be opened and closed with the help of Servo Motors. At railway crossings, LED lights serve as traffic signals, while a buzzer alerts drivers to the impending approach of a train. The proposed system uses an ultrasonic sensor, which is placed 7 kilometres away from the railway crossing, to detect the arrival of trains. Once the sensor detects a train, it sends a signal to the microcontroller, which then closes the gates at the crossing and activates a buzzer to warn pedestrians. Similarly, the microcontroller is instructed to shut off the buzzer signal, switch on the green LED signal, and unlock the railway platforms when the leaving ultrasonic sensor detects the train leaving the station.

V. BLOCK DIAGRAM

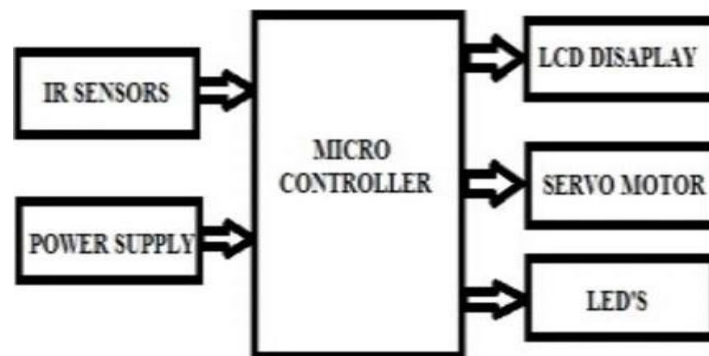

Sensors are employed in the proposed system to monitor train movement. The System regulates train arrivals and departures using data from three separate sensors. The sensors are programmed using an Arduino. Our suggested model's functionality is shown in Fig. I. The automated gateway control system that we propose uses the following materials and components. The functionality of our suggested system is shown in a block diagram in Fig. I. Where an IR sensor or Servo Motor, for example, may be connected to an Arduino. When the proposed model detects a train or the motion of any other vehicle near the crossing, the gateway either opens or closes as appropriate. The actuator is used for monitoring the crossway, and the IR sensors are used to detect the motion of things around the crossing.

VI. HARDWARE

1. Arduino
2. IR Sensors
3. Servo Motors
4. LCD Display
5. LED'S



IR-An infra (IR) sensor is a kind of electrical gadget used to detect and quantify IR radiation. William an astronomer, stumbled across infrared radiation by chance around the year 1800. Using a prism to separate the various wavelengths of light, he discovered that the temperatures just beyond the red light was greatest. As the wavelength of infrared is greater than that of visible light, it cannot be seen by the naked eye (though it is still on the same electromagnetic spectrum). Infrared radiation is emitted by any object with a temperature greater than around five degrees Kelvin. Active and passive infrared sensors both exist. Active infrared sensors are able to both send out and pick up rays of infrared light. There are two primary components of active IR sensors: an LED and a receiver. The sensor works by sending out an infrared signal from an LED, which is picked up by the receiver when an item passes within range. As proximity sensors, active IR sensors find widespread use in obstacle detection systems (such as in robots).



Lcd Connections: Depending on how many lines are used for connection to the microcontroller, there are 8-bit and 4bit LCD modes. The appropriate mode is determined at the beginning of the process in a phase called "initialization". In the first case, the data are transferred through outputs DO-D7 as it has been already explained. In case of 4-bit LED mode, for the sake of saving valuable I/O pins of the microcontroller, there are only 4 higher bits (D4-D7) used for communication, while other may be left unconnected.



Consequently, each data is sent to LCD in two steps: four higher bits are sent first (that normally would be sent through lines D4-D7), four lower bits are sent afterwards. With the help of initialization, LCD will correctly connect and interpret each data received. Besides, with regards to the fact that data are rarely read from LCD (data mainly are transferred from microcontroller to LCD) one more I/O pin may be saved by simple connecting WW pin to the Ground. Such saving has its price. bygnkygp though message displaying will be normally performed, it will not be possible to read from busy flag since it is not possible to read from display.

Motor: motor is an electrical device which can be used to rotate objects (like robotic arm) precisely. motor consists of DC motor with error sensing negative feedback mechanism. This allows precise control over angular velocity and position of motor. In some cases, AC motors are is a closed loop system where it uses negative feedback to control motion and final position of the sb@tUkis not used for continuous rotation like conventional AC/DC motors. It has rotation angle that varies from 0° to 360° .





module:Description Trame light The Traffic Light Module reproduces a two-way traffic light, complete with pedestrian signals and the possibility to simulate broken lights. Its realistic appearance and functionalities help make the Traffic Light Training System, Model 8075-1, vivid and compelling to students.



VII. RESULT

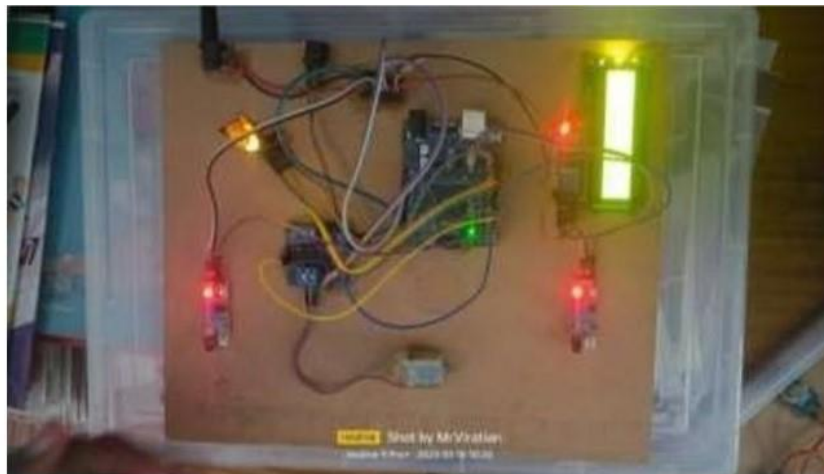

VIII. CONCLUSION

The suggested approach was able to ensure the protection of people in dangerous situations, such as at a railway platforms. The motor and mi amigo like IR and Ultrasonic sensor processes are combinable to make a system where a device or train itself is sensed if this passes the gateway and resulting actions are taken by motor to either open or shut the gateway, also the buzzer is used for trying to warn the nearby area about the arrival of carriage which reduces the rate of accidents near the railway crossings. The sensors are placed at an authentic distance from the gates so that there is sufficient warning time for the arrival of the train or its departure, and at that time the gateway may be closed or opened using a motor.



REFERENCES

- [1]. Y.Mallikarjuna Rao et. al, "Adaptive Leaf Abnormality Segmentation and Improved Plant Disease Classification by Tuned LSTM with RNN", *Concurrency and Computation — Practice and Experience*, Wiley— SCIE.
- [2]. Y.Mallikarjuna Rao et. al, "A Model Predictive Control Algorithm based active islanding detection for grid integrated photovoltaic systems", *Microprocessors and Microsystems*, Vol.95, 2022, — SCIE
- [3]. Y.Mallikarjuna Rao, M.V.Subramanyam and K. Satyaprasad, "QRS based mobility management algorithms for wireless mesh networks", *Journal of scientific and industrial research*, volume. 77, pp. 203-207, 2018. (Impact factor — 0.534, SCI Indexed)
- [4]. Y.Mallikarjuna Rao, M.V.Subramanyam and K. Satyaprasad, "Cluster based mobility management algorithms for wireless mesh networks", *International Journal of Communication systems (Wiley)*, Vol. 31, no. 11, pp. 114, 2018. (Impact factor — 1.717, SCI Indexed)
- [5]. Y.Mallikarjuna Rao, M.V.Subramanyam and K. Satyaprasad, "Cluster based hybrid routing protocol for wireless mesh networks", *Wireless personal communications — An international journal (Springer)*, Vol. 103, no.4, pp. 3009-3023, 2018. (Impact factor - 1.2, SCI Indexed)
- [6]. Y.Mallikarjuna Rao, M.V.Subramanyam and K. Satyaprasad, "Multi layer routing protocol for mobility management in wireless mesh networks", *Twelfth International Conference on Communication Networks*, 1921 August 2016, VTU, Bangalore, computer science- journal (Elsevier), 2016. (Scopus Indexed)
- [7]. Rao, K. "An efficient resource management algorithms for mobility management in wireless mesh networks", *IEEE Conference on energy, communication, data analytics and soft computing*, SKR Engineering College, Chennai, 2017. (Scopus Indexed)
- [8]. Y.Mallikarjuna Rao "A Review on Beamforming Approaches for Speech Enhancement", *International Journal of Control and Automation*, volume. 13, No. 4, pp. 590-595, 2020. (Scopus Indexed)
- [9]. Y.Mallikarjuna Rao, M.V.Subramanyam and K. Satyaprasad, "An enhanced mobility management algorithms for wireless mesh networks", *International Conference on advances in engineering management and sciences*, Santhiram Engineering College, Nandyal, 16-17 July 2017.
- [10]. Y.Mallikarjuna Rao, M.V.Subramanyam and K. Satyaprasad, "Performance analysis of energy aware QoS enabled routing protocol for wireless mesh networks", *International journal of smart grid and green (Accepted for communications, Inderscience publishers. (Accepted publication- UGC approved Journal))*.
Nikesh Gondchawar, Prof. Dr. R.S. Kawitkar, "IoT based Smart Agriculture", June 2016, *International Journal of Advanced research in Computer and Communication Engineering*.
- [12] Dr. N. Suma, Sandra Rhea Samson, S. Saranya, G. Shanmugapriya, R. Subhashri, "IoT Based Smart Agriculture Monitoring System", February 2017, *International Journal on Recent and Innovation Trends in Computing and Communication*.
- [13] Dr. "Internet of Things (IoT) based Smart Agriculture in India: An Overview", 2021, *Journal of ISMAC*, vol No. 3/NO. 1.
- [14] Sridevi Navulur, A.S.C.S. M.N. Prasad, "Agricultural Management through Wireless Sensors and Internet of Things", December 2017, *International Journal of Electrical and Computer Engineering (IJECE)*.
- [15] R. Sandhini, S. Poovizhi, Priyanka Jose, R. Ranjitha, Dr. S. "Arduino Based Smart Irrigation System Using IoT", 2017, *Intelligent Information and Computing Technologies, IICT*.
- [16] "based Smart Irrigation System", February 2017, *International Journal of Computer Applications*. [17] kg. p.Ü, "Smart Farming: Based Smart Sensors Agriculture Stick for Live Temperature and Moisture Monitoring using Arduino, Cloud Computing & Solar Technology", November 2016, *Research Gate*.
- [18] C. Vijay S. "Implementation of Wireless Sensor Network for Real Time Monitoring of Agriculture", May 2016, *International Research Journal of Engineering and Technology (IPJET)*.
- [19] Jianhan Lin, Maohua Wang, Miao Zhang, Zhang, Li Chen, "Electrochemical Sensors for Soil Nutrient Detection: Opportunity and Challenge", *Key Laboratory of Modern Precision Agriculture System Integration*, Ministry of Education, Beijing, China, 100083.
- [20] Ayagu Jain, Akhyy Kumar, "Smart Agriculture Monitoring System using IoT", July 2020, *International Journal for Research in Applied Science and Engineering Technology (IR.JASFT)*.